

第9章 线性动态电路暂态过程的 复频域分析

开课教师： 王灿

开课单位： 机电学院--电气工程学科



9.4 复频域中电路定律与电路模型

一、复频域中的基尔霍夫定律

时域

复频域

KCL: $\sum i_k(t) = 0$



$$\sum I_k(s) = 0$$

在集中参数电路中，流出
(入)节点的各支路**电流**
象函数的代数和为零。

KVL: $\sum u_k(t) = 0$



$$\sum U_k(s) = 0$$

在集中参数电路中，沿任
一回路各支路**电压**
象函数的代数和为零。

二、复频域中元件VCR方程及电路模型

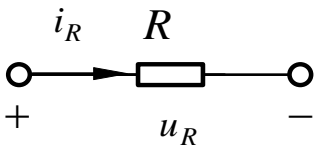
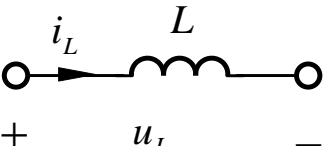
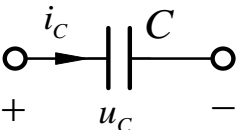
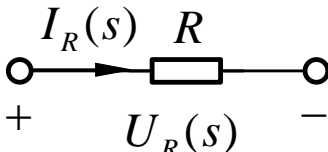
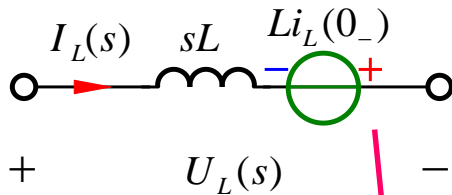
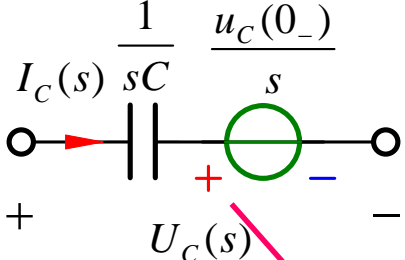
	电阻	电感	电容
时域模型			
时域VCR	$u_R = Ri_R$	$u_L = L \frac{di_L}{dt}$	$i_C = C \frac{du_C}{dt}$
复频域VCR	$U_R(s) = RI_R(s)$	$U_L(s) = sLI_L(s) - Li_L(0_-)$	$I_C(s) = sCU_C(s) - Cu_C(0_-)$ $U_C(s) = \frac{1}{sC} I_C(s) + \frac{u_C(0_-)}{s}$
复频域模型			

电感续流的方向

电容放电的方向

互感元件

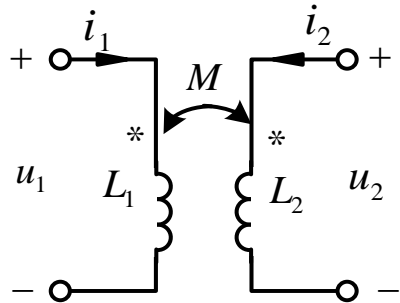

$$\begin{cases} u_1 = L_1 \frac{di_1}{dt} + M \frac{di_2}{dt} \\ u_2 = M \frac{di_1}{dt} + L_2 \frac{di_2}{dt} \end{cases}$$

$$\begin{cases} U_1(s) = sL_1 I_1(s) + sMI_2(s) - L_1 i_1(0_-) - Mi_2(0_-) \\ U_2(s) = sMI_1(s) + sL_2 I_2(s) - Mi_1(0_-) - L_2 i_2(0_-) \end{cases}$$

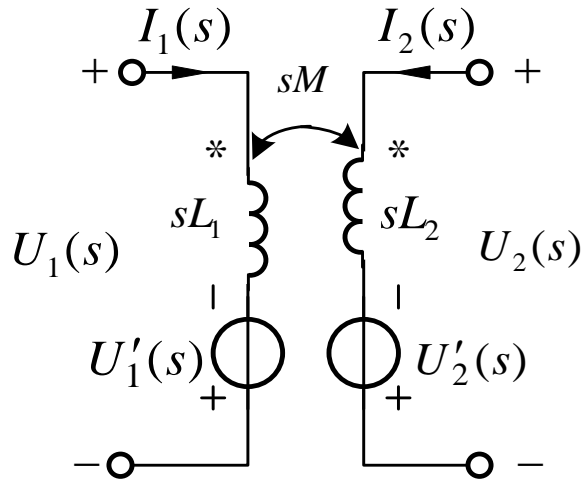

$$\begin{cases} U'_1(s) = L_1 i_1(0_-) + M i_2(0_-) \\ U'_2(s) = M i_1(0_-) + L_2 i_2(0_-) \end{cases}$$

三、复频域中电路模型

运算阻抗和运算导纳

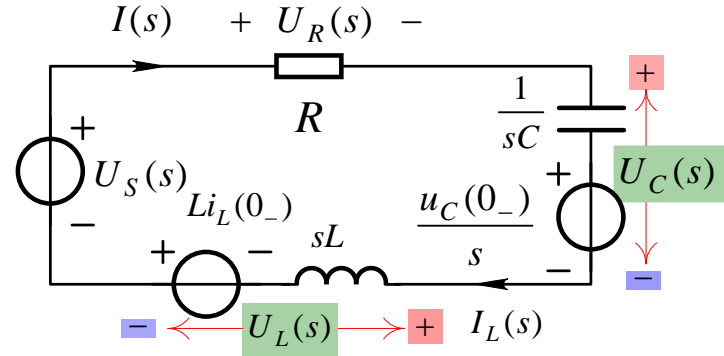
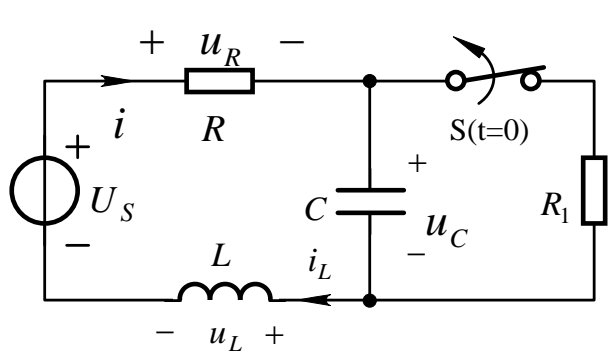

$$i_L(0_-) = i(0_-) = \frac{U_S}{R + R_1} \neq 0$$

$$u_C(0_-) = R_1 i(0_-) \neq 0$$

$$U_R(s) + U_C(s) + U_L(s) = U_S(s)$$

$$RI(s) + \left[\frac{1}{sC} I(s) + \frac{u_C(0_-)}{s} \right] + [sLI(s) - Li_L(0_-)] = U_S(s)$$

$$\left(R + sL + \frac{1}{sC} \right) I(s) = U_S(s) + Li_L(0_-) - \frac{u_C(0_-)}{s}$$

运算阻抗:

$$Z(s) = R + sL + \frac{1}{sC}$$

零状态时

$$u_C(0_-) = 0$$

$$i_L(0_-) = 0$$

$$\frac{U_S(s)}{I(s)} = Z(s)$$

$$\frac{I(s)}{U_S(s)} = \frac{1}{Z(s)} = Y(s)$$

运算导纳

9.5 用拉普拉斯变换分析线性动态电路的暂态过程

运算电路具体分析步骤

1. 确定换路前电路全部电容电压和电感电流： $u_C(0_-)$ 、 $i_L(0_-)$ ，并将激励的时域函数变换成象函数；
2. 根据换路后的电路画出运算电路。
其中 $u_C(0_-)$ 和 $i_L(0_-)$ 的作用用附加电压源表示，参数 (R 、 L 、 C) 用运算阻抗表示，已知的和待求的电压电流均用象函数表示；
3. 将前面所学习的各种计算方法求解，响应的象函数；
4. 利用部分分式展开法或积分变换表将响应的象函数变换为时域原函数。

【补充例题5】

图示电路，已知 $u_s = U_s \varepsilon(t)$, $u_C(0_-) = 0$ ，求输出电压 $u_C(t)$

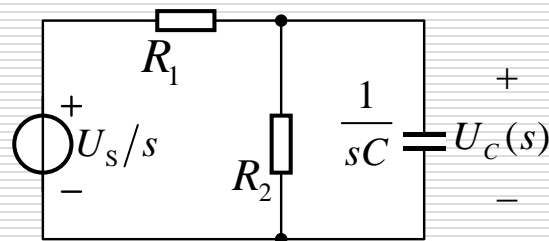
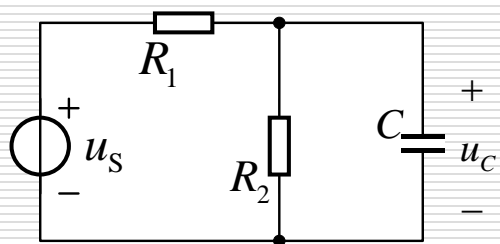

方法一：时域三要素法

$u_C(0_+) = u_C(0_-) = 0$ 零状态响应

$$u_C(\infty) = \frac{R_2 U_s}{R_1 + R_2} \quad \tau = RC$$

$(R = R_1 // R_2)$

$$u_C(t) = u_C(\infty)(1 - e^{-t/\tau})\varepsilon(t)$$

$$= \frac{R_2 U_s}{R_1 + R_2} (1 - e^{-t/RC})\varepsilon(t)$$

方法二：复频域法

$$\left(\frac{1}{R_1} + \frac{1}{R_2} + sC \right) U_C(s) = \frac{U_s/s}{R_1}$$

$$U_C(s) = \frac{U_s/CR_1}{s(s+1/RC)} = \frac{R_2 U_s}{R_1 + R_2} \left(\frac{1}{s} - \frac{1}{s+1/RC} \right)$$

$$u_C(t) = \frac{R_2 U_s}{R_1 + R_2} (1 - e^{-t/RC})\varepsilon(t)$$

【补充例题6】

图(a)所示电路，开关接通前处于稳态。已知 $U_1=1\text{V}, U_2=2\text{V}$
 $R_1=2\Omega, R_2=R_3=4\Omega, L=(5/6)\text{H}, C=0.2\text{F}$ ，求开关接通后电容电压 u 。

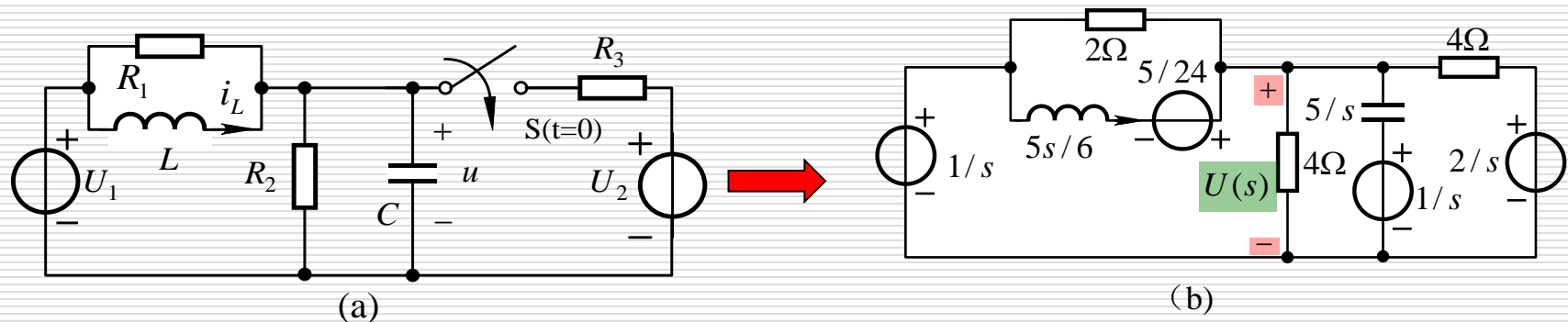

解： $t < 0$

$$u(0_-) = U_1 = 1\text{V} \quad i_L(0_-) = U_1 / R_2 = 0.25\text{A}$$

$$\left(\frac{1}{2} + \frac{1}{4} + \frac{1}{4} + 0.2s + \frac{1}{5s/6}\right)U(s) - \left(\frac{1}{2} + \frac{1}{5s/6}\right) \times \frac{1}{s} = \frac{2/s}{4} + \frac{1/s}{5/s} + \frac{5/24}{5s/6}$$

$$U(s) = \frac{s^2 + 6.25s + 6}{s(s^2 + 5s + 6)} = \frac{A_1}{s} + \frac{A_2}{s+2} + \frac{A_3}{s+3} \rightarrow A_1 = \frac{s^2 + 6.25s + 6}{(s+2)(s+3)} \Big|_{s=0} = 1\text{Vs}$$

$$A_2 = \frac{s^2 + 6.25s + 6}{s(s+3)} \Big|_{s=-2} = 1.25\text{Vs}$$

$$A_3 = \frac{s^2 + 6.25s + 6}{s(s+2)} \Big|_{s=-3} = -1.25\text{Vs}$$

$$u(t) = \mathbf{L}^{-1}\{U(s)\} = (1 + 1.25e^{-2t} - 1.25e^{-3t})\text{V}$$

【例题9.10】

图 (a) 所示电路中，已知 $R_1 = 9\Omega$ ， $R_2 = 1\Omega$ ， $C_1 = 1\text{F}$ ， $C_2 = 4\text{F}$ 外加电压 $u_s = 10\varepsilon(t)\text{V}$ ，电路为零状态。求电流 i 和电压 u_o 。

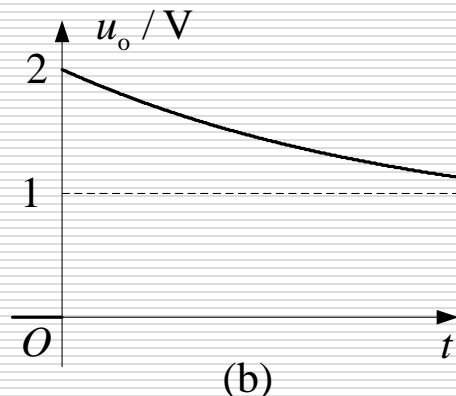
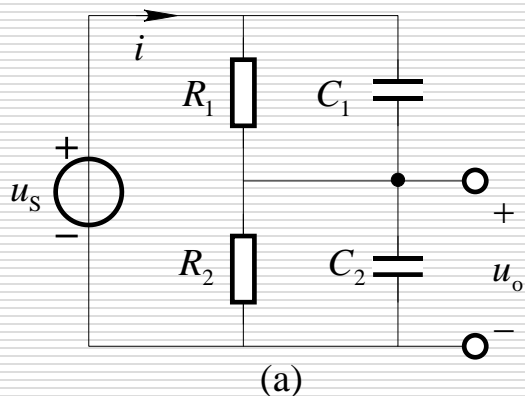

$$I(s) = \frac{U_s(s)}{Z(s)} = \frac{10(9s+1)(4s+1)}{s(45s+10)}$$

$$= 8 + \frac{1}{s} + \frac{(1/9)}{s+1/4.5}$$

$$i = 8C \times \delta(t) + \left(1 + \frac{1}{9}e^{-t/4.5}\right)\varepsilon(t)\text{A}$$

【解】零状态，运算电路中

无附加电源 $U_s(s) = 10\text{V/s}$

$$Z(s) = \frac{R_1 \times \frac{1}{sC_1}}{R_1 + \frac{1}{sC_1}} + \frac{R_2 \times \frac{1}{sC_2}}{R_2 + \frac{1}{sC_2}} = \frac{R_1 R_2 (C_1 + C_2)s + R_1 + R_2}{(R_1 C_1 s + 1)(R_2 C_2 s + 1)}$$

$$= \frac{45s + 10}{(9s + 1)(4s + 1)}$$

$$U_o(s) = I(s) \times \frac{R_2 \times \frac{1}{sC_2}}{R_2 + \frac{1}{sC_2}}$$

$$= \frac{1}{s} + \frac{1}{s + 1/4.5}$$

$$u_o = (1 + e^{-t/4.5})\text{V} \text{ 见图(b)}$$

【补充例题7】

图(a)所示电路开关断开前处于稳态。求开关断开后电路中 i_1 、 u_1 和 u_2

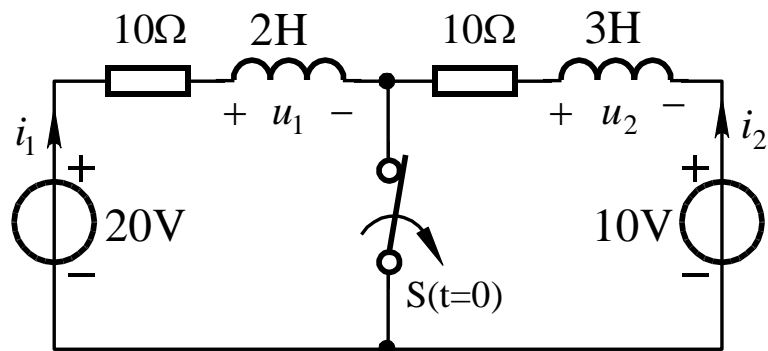

(a)

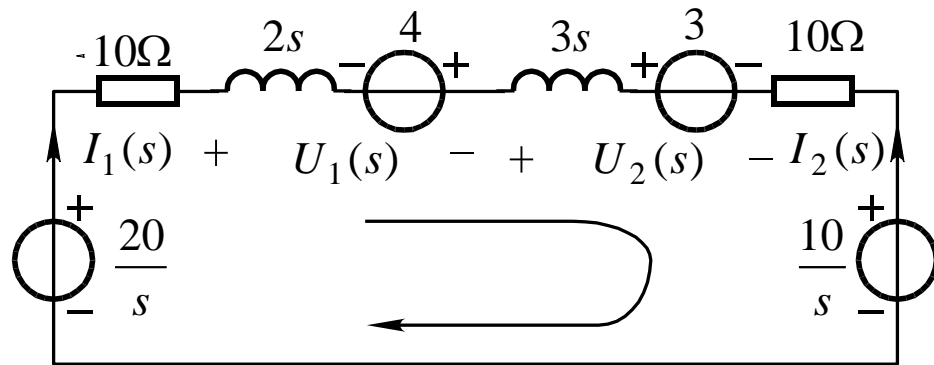

(b)

解: $t < 0$

$$i_1(0_-) = \frac{20\text{V}}{10\Omega} = 2\text{A}$$

$$i_2(0_-) = \frac{10\text{V}}{10\Omega} = 1\text{A}$$

$$i_1(t) = \mathbf{L}^{-1}\{I_1(s)\} = (0.5 - 0.3e^{-4t})\text{A}$$

$$u_1(t) = -3.6 \text{ Wb} \times \delta(t) + 2.4e^{-4t} \varepsilon(t) \text{ V}$$

$$u_2(t) = 3.6 \text{ Wb} \times \delta(t) + 3.6e^{-4t} \varepsilon(t) \text{ V}$$

$$(10 + 2s + 3s + 10)I_1(s) = \frac{20}{s} + 4 - 3 - \frac{10}{s}$$

$$I_1(s) = \frac{2 + 0.2s}{s(s + 4)} = \frac{0.5}{s} - \frac{0.3}{s + 4}$$

$$U_1(s) = 2sI_1(s) - 4 = -3.6 + \frac{2.4}{s + 4}$$

$$U_2(s) = 3sI_1(s) + 3 = 3.6 + \frac{3.6}{s + 4}$$

【补充例题8】

图(a)所示电路原处于稳态，在 $t=0$ 时将开关接通。求出电压 u_2 的象函数 $U_2(s)$ ，判断此电路的暂态过程**是否振荡**，利用拉普拉斯变换的初始值和终值定理求 u_2 的**初始值**和**稳态值**。

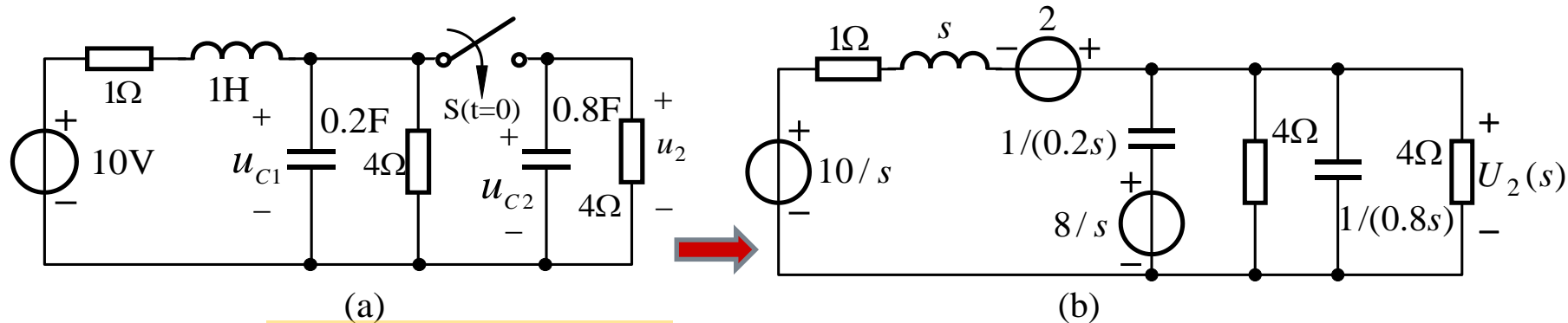

解: $t < 0$

$$i_L(0_-) = \frac{10V}{(4+1)\Omega} = 2A$$

$$u_{C1}(0_-) = 4\Omega \times i_L(0_-) = 8V$$

$$u_{C2}(0_-) = 0$$

$$\left(\frac{1}{s+1} + 0.2s + 0.8s + \frac{1}{4} + \frac{1}{4}\right)U_2(s) = \frac{(10/s) + 2}{s+1} + \frac{8/s}{1/(0.2s)} \rightarrow U_2(s) = \frac{1.6s^2 + 3.6s + 10}{s(s^2 + 1.5s + 1.5)}$$

初始值 $u_2(0_+) = \lim_{s \rightarrow \infty} sU_2(s) = 1.6V$

稳态值 $u_2(\infty) = \lim_{s \rightarrow 0} sU_2(s) = (20/3)V$

$$b^2 - 4ac = 1.5^2 - 4 \times 1 \times 1.5 = -3.75 < 0$$

存在共轭极点 \rightarrow 振荡

【例题9.13】

图 (a) 所示电路，已知 $R_1 = 1\Omega$ ， $R_2 = 1.5\Omega$ ， u_s 、 i_s 为阶跃函数。当 a、b 端接 $R_3 = 3\Omega$ 电阻时，全响应 $i = (2 + 2e^{-50t})\varepsilon(t)\text{A}$ ，现将 a、b 端改接 $L = 0.25\text{H}$ 的零状态电感，求此时的电压 u_{ab}

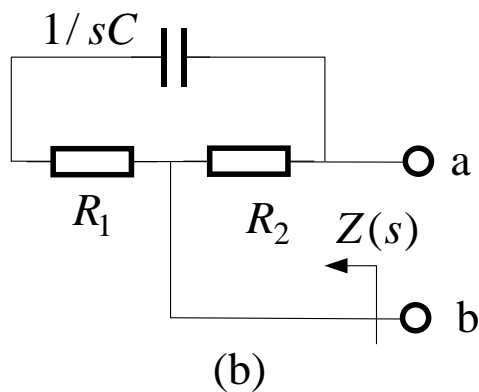
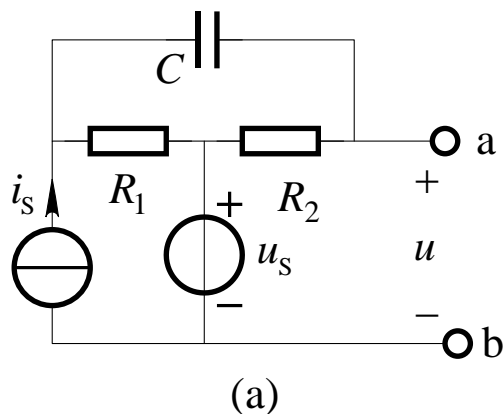

【解】 戴维南电路

等效运算阻抗如图(b)

时间常数

$$\tau = \frac{1}{50} \text{s} = RC = \left(R_1 + \frac{R_2 \times R_3}{R_2 + R_3} \right) C = 2C$$

$$C = \frac{\tau}{2} = 0.01\text{F}$$

$$Z(s) = \frac{R_2 \left(R_1 + \frac{1}{sC} \right)}{R_2 + R_1 + \frac{1}{sC}} = \frac{0.6s + 60}{s + 40}$$

【例题9.13】

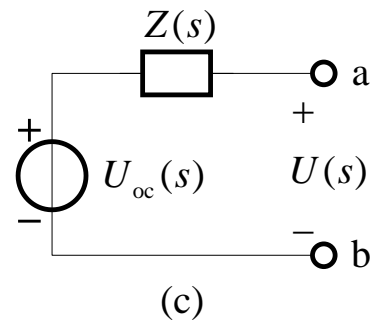
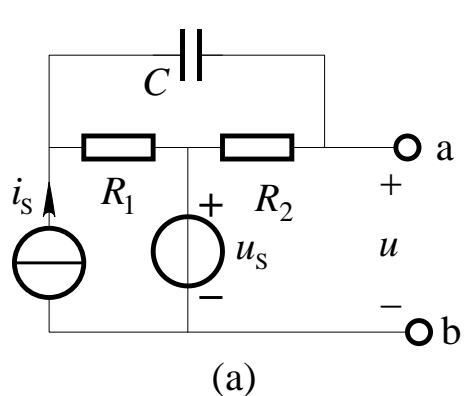

戴维南电路如图(c)

$$I(s) = \mathbf{L}\{i\} = \left(\frac{2}{s} + \frac{2}{s+50}\right) = \frac{4s+100}{s(s+50)} \rightarrow U_{oc}(s) = I(s)[Z(s) + R_3] = \frac{14.4s + 360}{s(s+40)}$$

接 $L=0.25\text{H}$ 的零状态电感时，**电感电压象函数**

$$U_{ab}(s) = \frac{sL}{sL + Z(s)} U_{oc}(s) = \frac{14.4s + 360}{s^2 + 42.4s + 240}$$

$$u_{ab} = \mathbf{L}^{-1}\{U_{ab}(s)\} = (9.09e^{-6.73t} + 5.31e^{-35.67t})\text{V} \quad (t > 0)$$