

## MSP430F5529 LaunchPad™ Development Kit (MSP-EXP430F5529LP)

The MSP430™ LaunchPad™ development kit now has USB. The MSP-EXP430F5529LP is an inexpensive and simple development kit for the MSP430F5529 USB microcontroller. It offers an easy way to start developing on the MSP430 MCU, with onboard emulation for programming and debugging as well as buttons and LEDs for a simple user interface.

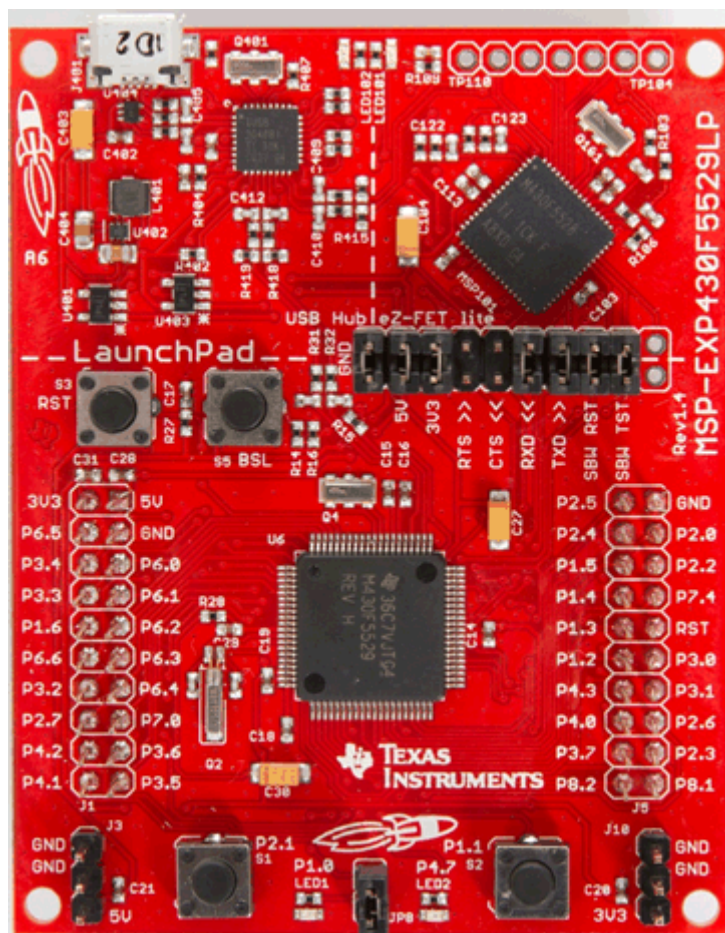

**Figure 1. MSP430F5529 LaunchPad Development Kit**

## Contents

1	Getting Started .....	4
2	Hardware.....	9
3	Software Examples .....	28
4	Additional Resources .....	48
5	FAQs.....	52
6	Schematics.....	54

## List of Figures

1	MSP430F5529 LaunchPad Development Kit .....	1
2	Jumper Requirements Necessary for Software Demo.....	5
3	Storage Volume, Mounted from the MSC Interface.....	6
4	Files on the Storage Volume .....	6
5	Default Text Typed From Button S1 .....	7
6	ASCII-Art Rocket, Typed from Button S2.....	8
7	EVM Features and Controls.....	9
8	Block Diagram .....	10
9	MSP430F5529 Pinout .....	11
10	eZ-FET lite Emulator.....	12
11	Onboard USB Bus Path .....	13
12	F5529 LaunchPad Development Kit USB Interfaces .....	14
13	F5529 LaunchPad Development Kit Power Supply .....	14
14	Backchannel UART Pathway .....	16
15	Application Backchannel UART in Device Manager.....	16
16	Isolation Jumper Block .....	17
17	Power Block Diagram for Default Configuration With USB Power Only .....	19
18	Power Block Diagram for External 3.3-V Power Source .....	20
19	Power Block Diagram for External 5-V Power Source Without USB Connection .....	21
20	Power Block Diagram for External 5-V Power Source With USB Connection .....	22
21	USB BSL Button.....	23
22	Identifying the USB BSL HID Interface in Device Manager .....	24
23	F5529 LaunchPad Development Kit to BoosterPack Plug-in Module Connector Pinout .....	26
24	Browse to Demo Project for Import Function.....	29
25	When CCS Has Found the Project .....	29
26	F5529 LaunchPad Development Kit Demo Software Organization .....	30
27	MSP430 USB Descriptor Tool.....	31
28	Demo Program Flow.....	32
29	Disable the Watchdog in Pre-Initialization .....	33
30	Waking From LPM0.....	35
31	Movement of Data in simpleUsbBackchannel: CDC .....	39
32	simpleUsbBackchannel USB Virtual COM Port, Needing a Driver .....	40
33	Device Manager After Both Ports are Enumerated.....	41
34	Movement of Data in simpleUsbBackchannel: HID-Datapipe .....	46
35	Start Device Manager .....	46
36	Device Manager .....	47
37	F5529 LaunchPad Development Kit With DLP-7970ABP NFC BoosterPack Plug-in Module .....	48
38	USB Examples in the USB Developers Package .....	50
39	TI Resource Explorer: Create a New USB Project Wizard .....	51
40	Schematics (1 of 4) .....	54

41	Schematics (2 of 4) .....	55
42	Schematics (3 of 4) .....	56
43	Schematics (4 of 4) .....	57

### List of Tables

1	Files on the Storage Volume .....	6
2	eZ-FET lite LED Feedback Behavior .....	13
3	Isolation Block Connections .....	17
4	Hardware Change Log .....	27
5	Software Examples .....	28
6	Demo Project File and Directory Descriptions.....	30
7	Backchannel Library: Constants to Configure .....	42
8	Backchannel Library: Functions .....	42
9	Clock Settings .....	43
10	How MSP430 Device Documentation is Organized .....	48

### Trademarks

MSP430, LaunchPad, BoosterPack, Code Composer Studio are trademarks of Texas Instruments.  
 IAR Embedded Workbench is a trademark of IAR Systems.  
 All other trademarks are the property of their respective owners.

## 1 Getting Started

Rapid prototyping is simplified by the 40-pin BoosterPack™ plug-in module headers, which support a wide range of available BoosterPack plug-in modules. You can quickly add features like wireless connectivity, graphical displays, environmental sensing, and much more. You can either design your own BoosterPack plug-in module or choose among many already available from TI and third-party developers.

The MSP430F5529 16-bit MCU has 128KB of flash memory, 8KB of RAM, 25-MHz CPU speed, integrated USB, and many peripherals – plenty to get you started in your development.

Custom USB functionality can be quickly added using the free open-source USB tools and examples available in the [MSP430 USB Developers Package](#). This includes the MSP430 USB Descriptor Tool, which quickly customizes any combination of USB interfaces and automatically generates your USB descriptors for those interfaces.

Free software development tools are also available: TI's Eclipse-based Code Composer Studio™ IDE (CCS) and IAR Embedded Workbench™ IDE (IAR), and the community-driven [Energia](#) open-source code editor. More information about the LaunchPad development kit including documentation and design files can be found on the tool page at [www.ti.com/tool/msp-exp430f5529lp](http://www.ti.com/tool/msp-exp430f5529lp).

### 1.1 Key Features

- USB-enabled [MSP430F5529](#) 16-bit MCU
  - Up to 25-MHz System Clock
  - 1.8-V to 3.6-V operation
  - 128KB of flash, 8KB of RAM
  - Five timers
  - Up to four serial interfaces (SPI, UART, I<sup>2</sup>C)
  - 12-bit analog-to-digital converter
  - Analog comparator
  - Integrated USB, with a complete set of USB tools, libraries, examples, and reference guides
- The eZ-FET lite emulator, with the application ("backchannel") UART. (Now open-source!)
- Ability to emulate and develop USB applications with a single USB cable, made possible with an onboard USB hub
- Power sourced from the USB host. The 5-V bus power is reduced to 3.3 V, using an onboard dc-dc converter.
- Both male and female 40-pin BoosterPack plug-in module headers, configured for stacking. 20-pin BoosterPack plug-in modules can also be attached.
- Compatible with the 40-pin BoosterPack plug-in module development tool standard.

### 1.2 Kit Contents

- (1) MSP-EXP430F5529LP LaunchPad development kit
- (1) USB cable with "micro" connectors
- (1) Quick start guide

If you intend to write code for the F5529 LaunchPad development kit, you can complete the kit by downloading the [MSP-EXP430F5529LP Hardware Design Files](#) and the [MSP-EXP430F5529LP Software Examples](#) from the [MSP-EXP430F5529LP tool page](#).

### 1.3 Out-of-Box Experience

The F5529 LaunchPad development kit comes programmed with an out-of-box demonstration example. Let's get started!

This section only describes how to use the demo. More details about the F5529 LaunchPad development kit are given later.

The demo works on a Windows PC, Linux PC, or Mac. It requires that (at minimum) the power jumpers (3.3 V and 5 V) on the isolation jumper block be connected. These supply power to the target F5529 device. As shipped from TI, these jumpers are connected.

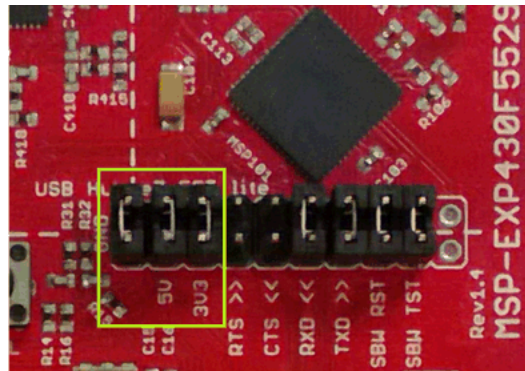

**Figure 2. Jumper Requirements Necessary for Software Demo**

### Step 1: Install a Software Development Platform

The development platform can be Code Composer Studio IDE (CCS), IAR Embedded Workbench IDE (IAR), mspgcc, or Energia open-source platform. See [Section 3.2](#) for help choosing a platform.

The out-of-box demo works without this step, but the host reports that the integrated eZ-FET lite emulator did not enumerate.

(Be aware that the USB API does not yet fully support mspgcc development, but mspgcc does contain the eZ-FET drivers.)

### Step 2: Connect the Hardware

Connect the LaunchPad development kit to a host PC using the USB cable included with the LaunchPad development kit. The demo should work on any recent version of these operating systems. If prompted, let the PC automatically install software. The install is "silent", which means that the PC's operating system already has the drivers it needs.

When you connect a USB device to your computer, the computer goes through the *enumeration* process. During enumeration, the host asks for the device's *USB descriptors* to learn the device's identity, capabilities, and more. Using the descriptors, the device presents one or more *USB interfaces* to the host, where each interface is associated with either a pre-defined *device class*, or a custom driver. The major operating systems already ship with drivers for most common device classes, which is why you do not need to provide them during installation.

The F5529 LaunchPad development kit software demo presents two USB interfaces to the host:

- A Mass Storage Class (MSC) interface, which results in a storage volume
- A Human Interface Device (HID) interface, which is configured as a keyboard

All major host operating systems already have drivers for these classes.

Note: The eZ-FET emulator, application UART, and USB hub also enumerate when the LaunchPad development kit is attached. These are part of the LaunchPad development kit emulator, and so they always enumerate on Windows and Linux PCs, no matter what software is loaded into the MSP430F5529 device. In contrast, the MSC and HID interfaces described in this section are generated by the software demo application that is loaded onto the LaunchPad development kit as shipped from TI. See [Section 2.2.3](#) for more information.

### Step 3: Verify the storage volume has been loaded

When you attach the LaunchPad development kit to the PC, a storage volume is mounted on the host. This volume can be seen in "My Computer", with the name "F5529LP":

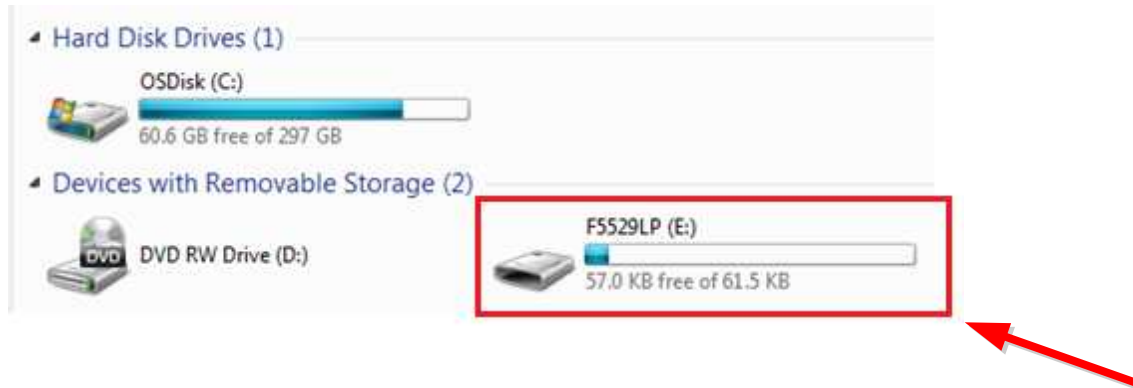

**Figure 3. Storage Volume, Mounted from the MSC Interface**

This storage volume is stored within the MSP430F5529's on-chip flash. It is small compared to most flash drives, but it is large enough for the demo's needs. The MSP430 software presents it to the host through the MSC interface.

If you open the volume, you see these files:

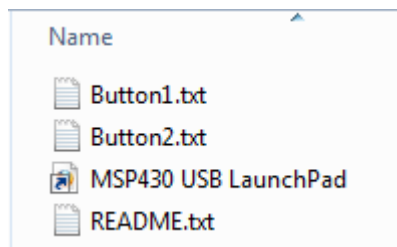

**Figure 4. Files on the Storage Volume**

Table 1 describes the function of these files.

**Table 1. Files on the Storage Volume**

File	Description
Button1.txt	Contains the text that will be "typed" by the keyboard interface when button S1 is pressed. By default, its contents are "Hello World".
Button2.txt	Contains the text that will be "typed" by the keyboard interface when button S2 is pressed. By default, it contains "ASCII art" of the LaunchPad development kit "rocket" logo.
MSP430 USB LaunchPad.url	Opening this file causes your web browser to launch the MSP-EXP430F5529LP LaunchPad development kit web page
README.txt	A "readme" file that helps explain how to use these files.

If you place other files inside the volume, they are stored inside flash of the MSP430 MCU. The volume is only approximately 60KB in size. If you later download the software demo (or any software) to the F5529 target, any data that you have placed in the volume will be lost.

If you change the name of the Button1.txt or Button2.txt file, the pushbutton functionality no longer works. This is because the MSP430 demo software looks for these files by name.

#### Step 4: Open a text editor, and press the buttons

In addition to the MSC interface, the other USB interface that is enumerated by the demo is an HID interface, which is used to emulate a keyboard. When you press the S1 or S2 button, the text stored in the Button1.txt or Button2.txt file, respectively, is sent to your computer as typed keystrokes.

To see the keyboard in action, open a text editor. If using Windows, the standard Notepad application is a good choice. (To open Notepad, click the Start button, then click Run..., type "notepad" in the Open text box, and click OK.)

Make sure the window focus is on the text editor and not on another application running on the PC. Then press the S1 button on the LaunchPad development kit to send the text in [Figure 5](#) to Notepad.

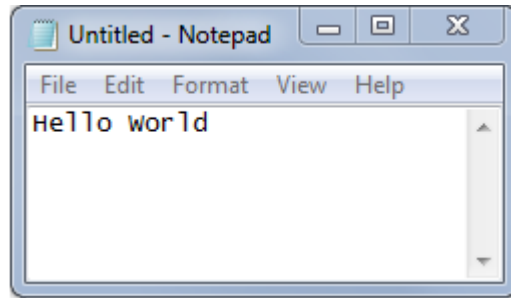

**Figure 5. Default Text Typed From Button S1**

Then delete this text, and press the S2 button on the Launchpad to send the text in [Figure 6](#) to Notepad.

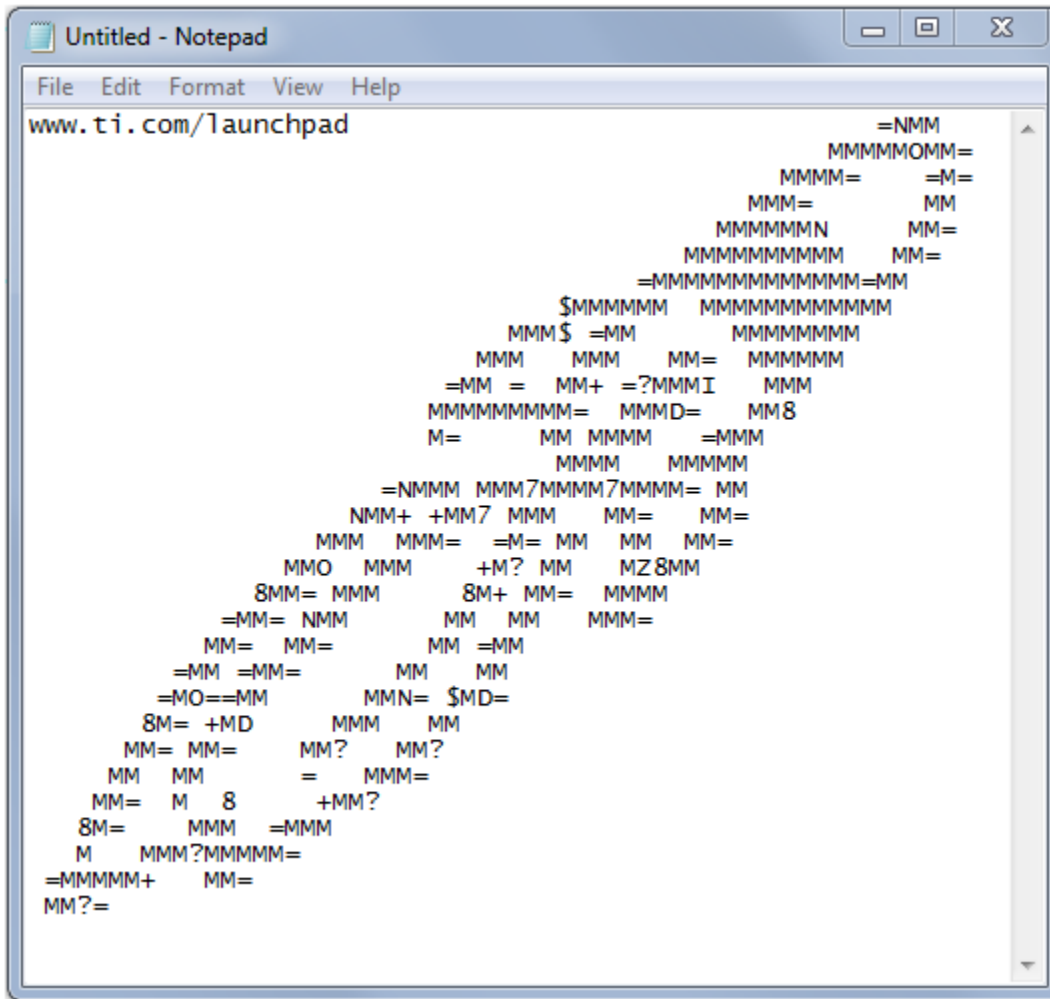

**Figure 6. ASCII-Art Rocket, Typed from Button S2**

The rocket can take a few seconds to type out. While the MCU is typing this out, be sure not to change the PC window focus outside of Notepad. If you change the focus, keystrokes will be sent to whatever application has focus, and strange things might happen on your PC.

**Step 5: Customize the strings**

Because the strings typed out by the S1 and S2 buttons originate from the Button1.txt and Button2.txt files, respectively, you can change these strings. Open these files in a text editor, modify their contents, and save the files. Then press the corresponding button; your new string is typed out.

There is a 2048-character limit on each string, a limit set within the software. The limit is necessary because the software reads the files' strings into a RAM buffer before typing, and the size of this RAM buffer is 2048 bytes.



## 2 Hardware

This section describes the F5529 LaunchPad development kit hardware.

Figure 7 shows the LaunchPad development kit, with its important features and configuration controls. These controls are described in this section.

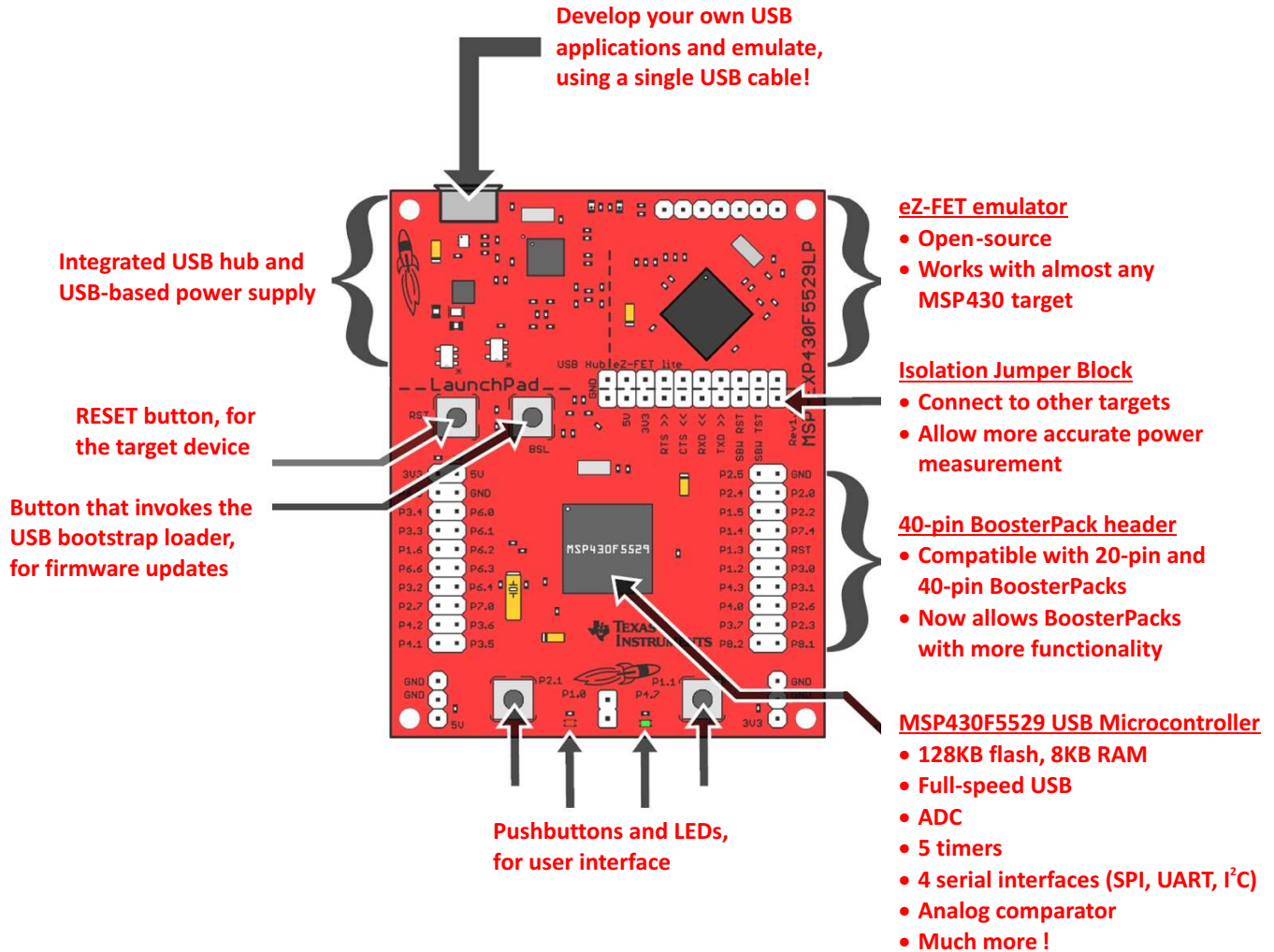

Figure 7. EVM Features and Controls

## 2.1 Block Diagram

Figure 8 shows a functional block diagram of the board.

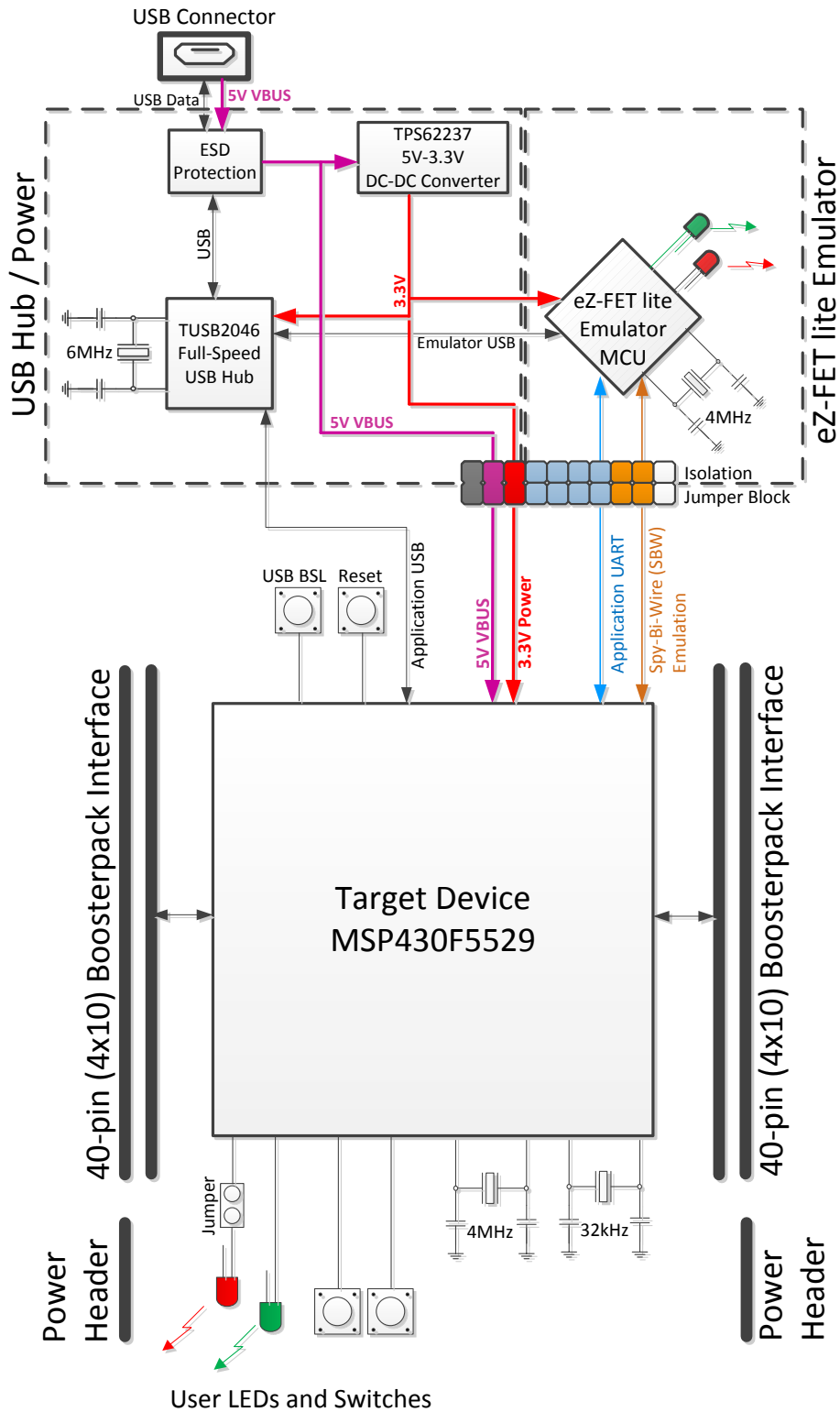

Figure 8. Block Diagram

## 2.2 Hardware Features

### 2.2.1 MSP430F5529

The MSP430F552x is one of several USB-equipped MSP430 MCU families. It offers:

- 1.8-V to 3.6-V operation
- Up to 25-MHz system clock
- 128KB flash memory, 8KB RAM (in addition to 2KB shared RAM with the USB module)
- Ultra-low-power operation
- Full-speed USB with 14 endpoints – enough for almost any USB application
- Five timers, up to four serial interfaces (SPI, UART, or I<sup>2</sup>C), 12-bit analog-to-digital converter, analog comparator, hardware multiplier, DMA, and more

Figure 9 shows the pinout of the MSP430F5529 in the PN package (LQFP).

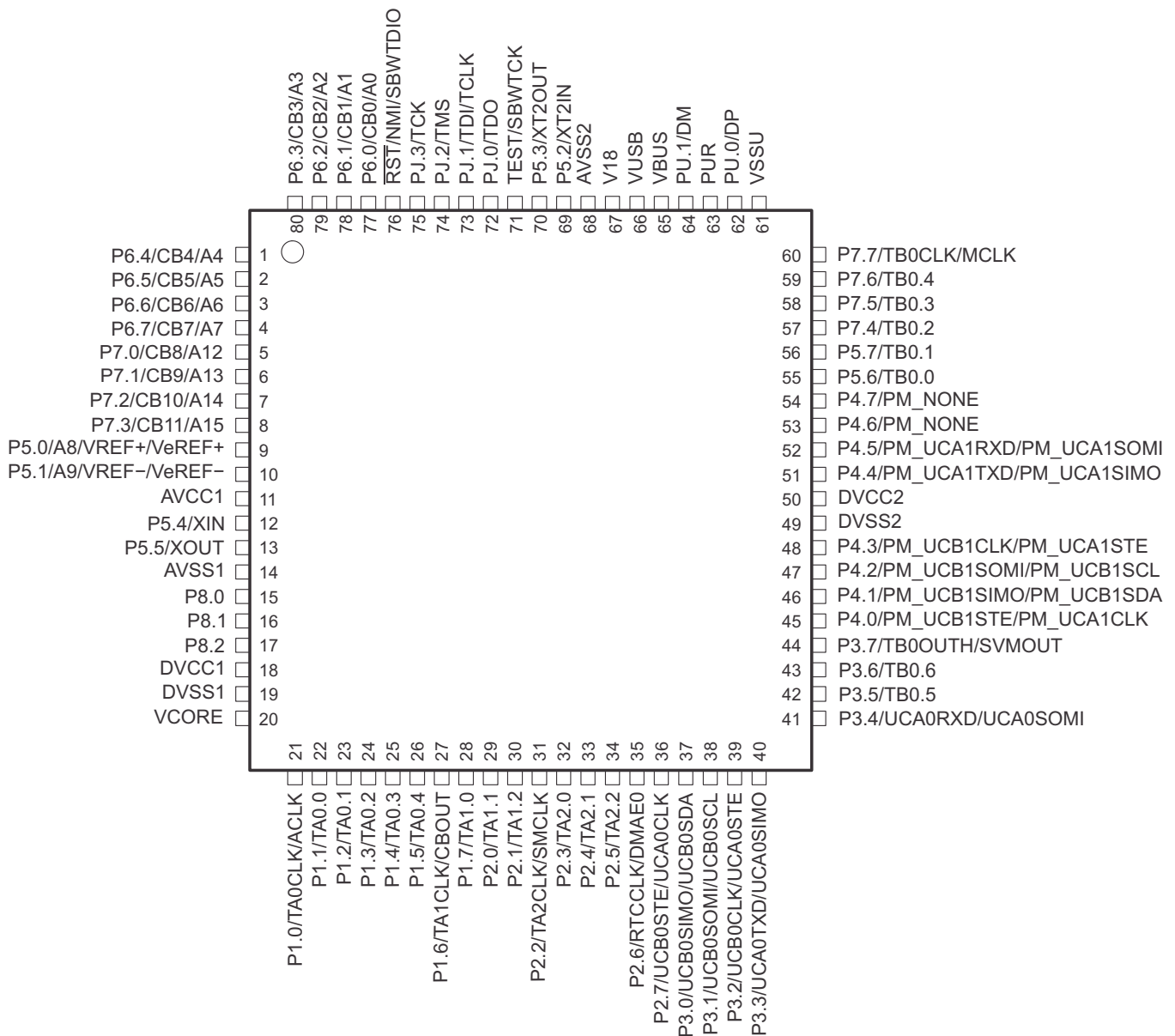

Figure 9. MSP430F5529 Pinout

Other USB-equipped MSP430 MCU families include the smaller F550x family and the larger F563x, F663x, F565x, and F665x families.

To compare the various MSP430 MCUs, download the [MSP430 Product Brochure](#), which is also available from <http://www.ti.com/msp430>. The brochure has a table that lets you see at a glance how the families compare and their pricing. This document is frequently updated as new MSP430 MCUs become available.

## 2.2.2 eZ-FET lite Onboard Emulator

To simplify development and keep the user's costs low, TI's LaunchPad development kit development tools integrate an emulator for programming and debugging. The F5529 LaunchPad development kit has the new eZ-FET lite emulator (see [Figure 10](#)).

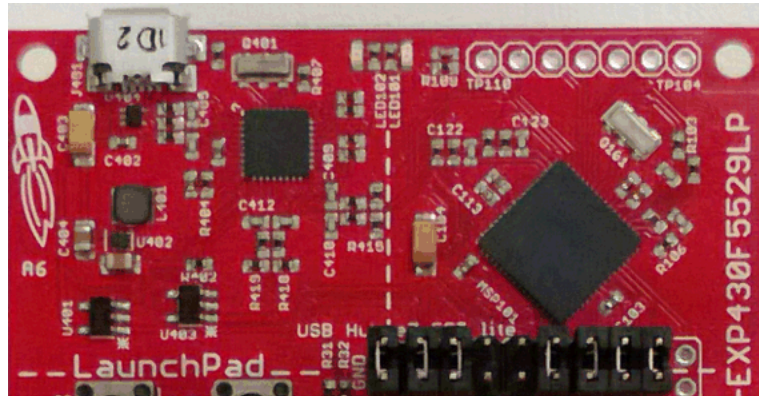

**Figure 10. eZ-FET lite Emulator**

The dotted line along the bottom of the image divides the emulator area from the target area. (On the board, the power and hub area that is shown in [Figure 8](#) is grouped with the emulator.)

The eZ-FET lite is simple and low cost. Like the emulator on the G2 LaunchPad development kit ([MSP-EXP430G2](#)), it provides a "backchannel" UART-over-USB connection with the host, which can be very useful during debugging. But unlike the G2 emulator, it:

- supports almost all MSP430 MCUs
- has a configurable backchannel UART baudrate
- is completely open source!

The hardware and firmware designs are both available for you to customize. Further details and source can be found on [http://processors.wiki.ti.com/index.php/EZ-FET\\_lite](http://processors.wiki.ti.com/index.php/EZ-FET_lite).

The eZ-FET lite needs a host-side interface. TI provides the "MSP430 DLL", through which PC applications can access the eZ-FET lite. Such applications include IAR or CCS software environments, MSP430Flasher, Elprotronic's FET-Pro430, mspgcc, and Energia. These solutions generally bundle the DLL.

On Windows, the MSP430 DLL is a DLL file, while on Linux it is a \*.so file. Like the rest of the eZ-FET lite solution, the DLL is open source.

Mac OS X has a limitation that prevents it from enumerating composite USB devices that include a CDC interface. For this reason, the eZ-FET lite currently does not work with the default OS X.

The eZ-FET lite works with almost all MSP430 target devices. If you want to work with a different target than the F5529 device on the F5529 LaunchPad development kit, you can disconnect the F5529 using the isolation jumper block and wire your hardware to the emulator through this block.

Features of the eZ-FET lite:

- USB debugging and programming interface
- No need to install a driver on the host Windows or Linux PC – it loads silently
- Application ("backchannel UART") virtual COM port connection with the host, over USB, up to 1 Mbaud
- LEDs for visual feedback
- Field-updatable firmware
- Supports almost all MSP430 MCUs

Hardware and software requirements

- PC with Windows or Linux
- MSP430.DLL 3.3.0.6 or higher

The eZ-FET lite LEDs provide feedback to the user about the emulator status (see [Table 2](#)). This behavior is similar to that of the MSP-FET430UIF emulator.

**Table 2. eZ-FET lite LED Feedback Behavior**

Green LED (Power)	Red LED (Mode)	Description
OFF	OFF	eZ-FET lite is not connected to the PC. eZ-FET lite is not ready (for example, after an update). Disconnect the LaunchPad development kit from the PC and reconnect it.
ON	OFF	eZ-FET lite is connected and ready, but the eZ-FET lite interface has not been opened by IDE.
ON	ON	eZ-FET lite interface is used by IDE, but no data transfer is taking place.
ON	Blinking	eZ-FET lite is in action: data transfer between eZ-FET lite and IDE is taking place.
OFF	ON	A severe ERROR has occurred; disconnect and reconnect the eZ-FET lite. If this does not resolve the error, send for repair.
Alternating green and red blinking		A critical update is running on the eZ-FET lite. <b>Do not interfere with it during this time.</b> Wait until it is finished.

### 2.2.3 Integrated Full-Speed USB Hub

The F5529 LaunchPad development kit requires only one USB connection to the host, thanks to an integrated USB hub (see [Figure 11](#)). The emulator and the target device share one USB cable and can be used simultaneously. This simplifies the development setup.

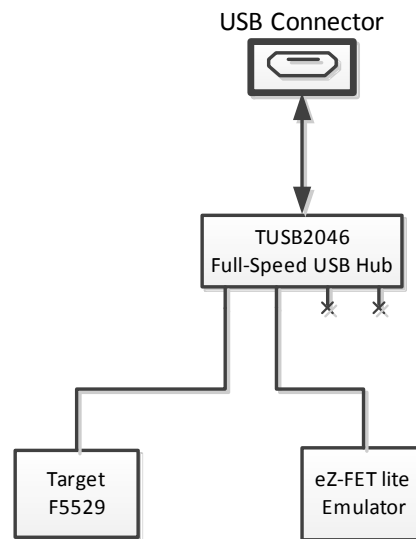

**Figure 11. Onboard USB Bus Path**

The eZ-FET lite emulator itself is a *composite* USB device, which means that it contains two USB interfaces:

- A CDC interface (virtual COM port) for the emulation function
- A CDC interface (virtual COM port) for the application UART

(For an explanation of USB interfaces, see the discussion in Step 2 of [Section 1.3](#))

These interfaces can be found on the host PC. As an example, Device Manager can be used for this purpose on a Windows PC. (See [Section 3.7](#) for instructions on starting Device Manager.) Look for the emulator interfaces under the "Ports" section (see [Figure 12](#)).

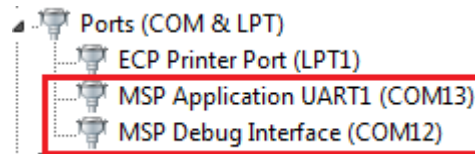

**Figure 12. F5529 LaunchPad Development Kit USB Interfaces**

If you are using a Mac, see [Section 2.2.2](#) for an explanation why these interfaces do not enumerate.

Although the MSP Debug Interface virtual COM port is accessible to any host application, do not try to interface with it; it is only intended for use with supported emulation tools, like CCS and IAR.

If you load a USB-equipped software application into the target MSP430F5529 device, then additional USB interfaces, defined by that software, will be enumerated on the host.

The TUSB2046 is a four-port hub, and two ports are unused. The unused ports are properly terminated and inaccessible.

### 2.2.4 Power

[Figure 13](#) shows the power segment of the block diagram.

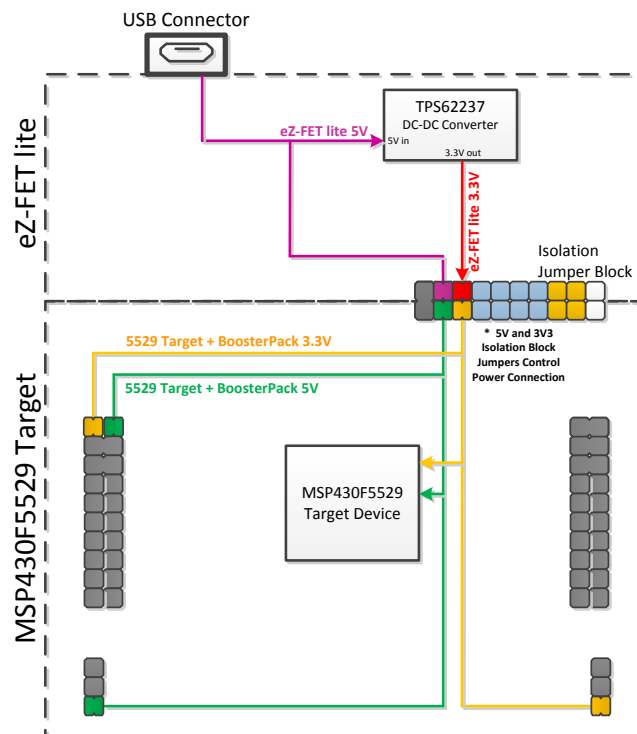

**Figure 13. F5529 LaunchPad Development Kit Power Supply**

USB hosts supply a 5-V power rail to USB devices, called "VBUS". This is convenient for USB devices; if they only need to function while attached to a host (for example, mice or keyboards) then they may not need their own power source. Even if they need to function apart from the USB host and, thus, need their own power source, being attached to the host places power demands on that device which may not be present when the device is not attached; the availability of VBUS can help offset these demands.

The F5529 LaunchPad development kit has a high-efficiency dc-dc converter, a [TPS62237](#), that derives a new power rail of 3.3 V from VBUS. This 3.3-V rail sources the eZ-FET lite, hub, target F5529 device, and the 3.3-V pin on the BoosterPack plug-in module header.

VBUS is still made available to the target F5529 device for two reasons. One reason is that the presence of VBUS is how a USB device determines the presence of a USB host. The other reason is that VBUS also supplies power to the target F5529 USB module.

USB-equipped MSP430 MCUs have an integrated 5-V to 3.3-V LDO. On the F5529 LaunchPad development kit, this LDO is only used for the MSP430F5529 USB operation. However, the integrated LDO also has an output pin that can source a modest amount of power to external circuitry. See the device data sheet for more details. Sometimes, this output pin can eliminate the need for external power management. But because the current limit may be too low for some applications, the F5529 LaunchPad development kit uses the external dc-dc converter.

If desired, 3.3 V can be supplied from an external source to the power header pin. But to do this, the 3.3-V jumper on the isolation jumper block must be disconnected. See [Section 2.4](#) for more information.

### 2.2.5 Clocking

The F5529 LaunchPad development kit provides two resonators on the target F5529:

- XT1: a 32-kHz crystal
- XT2: a 4-MHz ceramic resonator, within  $\pm 2500$ -ppm precision

The 32-kHz crystal allows for lower LPM3 sleep currents than do the other low-frequency clock sources. Therefore, the presence of the crystal allows the full range of low-power modes to be used.

USB operation on the MSP430F5529 requires a high-frequency reference clock for the USB PLL. To meet this need, the F5529 LaunchPad development kit has a 4-MHz ceramic resonator on the XT2 oscillator. This particular ceramic resonator operates within  $\pm 2500$  ppm, which is important for USB operation. If the F5529 application needs a high-frequency precision clock for purposes other than USB, then this clock is available for this as well.

For information on how clocks are configured by the software examples, see [Section 3.6.5.3](#).

### 2.2.6 Application (or "Backchannel") UART

The backchannel UART allows communication with the USB host that is not part of the target application main functionality. This is very useful during development. For example, if, while developing a USB interface, you want to send debug information to the host without using the USB interfaces under development to do so.

[Figure 14](#) shows the pathway of the backchannel UART. The backchannel UART (USCI\_A1) is independent of the UART on the 40-pin BoosterPack plug-in module connector (USCI\_A0).

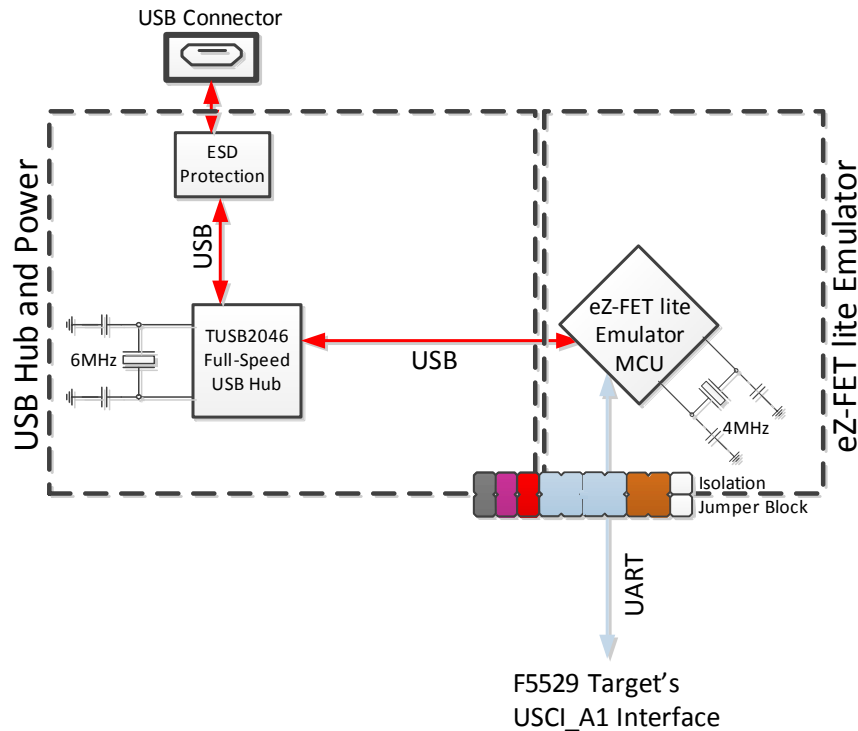

**Figure 14. Backchannel UART Pathway**

On the host side, a virtual COM port for the application backchannel UART is generated when the F5529 LaunchPad development kit enumerates on the host. You can use any PC application that interfaces with COM ports, including terminal applications like Hyperterminal or Docklight, to open this port and communicate with the target application.

You need to identify the COM port for the backchannel. On Windows PCs, Device Manager can assist (see [Figure 15](#)). (See [Section 3.7](#) for instructions on starting Device Manager.)

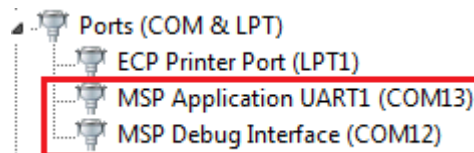

**Figure 15. Application Backchannel UART in Device Manager**

The backchannel UART is the port named "MSP Application UART1". In this example, the figure shows COM13, but the port number varies from one host PC to the next.

After you identify the correct COM port, configure it in your host application according to its documentation. You can then open the port and begin talking to it from the host.

On the target F5529 side, the backchannel is connected to the USCI\_A1 module.

Unlike the eZ-FET on the G2 LaunchPad development kit, this eZ-FET lite has a configurable baudrate. Therefore, it is important that the PC application configures the baudrate to be the same as what is configured on the USCI\_A1.



Also unlike the eZ-FET on the G2 LaunchPad development kit, this eZ-FET lite supports hardware flow control, if desired. Hardware flow control (CTS and RTS handshaking) allows the target F5529 and the emulator to tell each other to wait before sending more data. At slow baud rates and with simple target applications, flow control may not be necessary. An application with faster baud rates and more interrupts to service has a higher likelihood that it cannot read the USCI\_A1 RXBUF register in time, before the next byte arrives. If this happens, the USCI\_A1 UCA1STAT register will report an overrun error.

To implement the backchannel on the target F5529, a simple library is provided within the simpleUsbBackchannel example. It supports communication with and without hardware flow control. See [Section 3.6.4](#) for more information.

### 2.2.7 Emulator and Target Isolation Jumper Block

A set of ten jumpers is placed between the emulator and the F5529 target device. This is the isolation jumper block (see [Figure 16](#) and [Table 3](#)). Individual functions on the isolation block are described in the following sections.

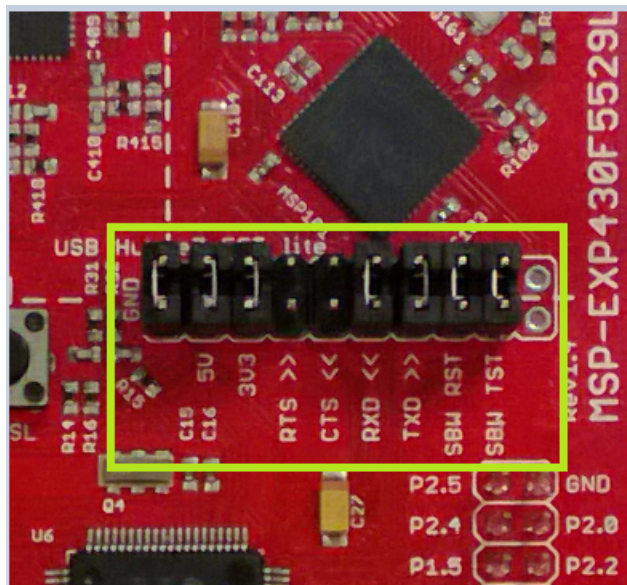

Figure 16. Isolation Jumper Block

Table 3. Isolation Block Connections

Jumper (from left to right)	Description
GND	Ground
5V	5-V VBUS, sourced from the USB host. The F5529 target needs this if attempting a USB connection with it.
3V3	3.3-V rail, derived from VBUS with a dc-dc converter
RTS >>	Backchannel UART: Ready-To-Send, for hardware flow control. The target can use this to indicate whether it is ready to receive data from the host PC. The arrows indicate the direction of the signal.
CTS <<	Backchannel UART: Clear-To-Send, for hardware flow control. The host PC (through the emulator) uses this to indicate whether it is ready to receive data. The arrows indicate the direction of the signal.
RXD <<	Backchannel UART: the target F5529 receives data through this signal. The arrows indicate the direction of the signal.
TXD >>	Backchannel UART: the target F5529 sends data through this signal. The arrows indicate the direction of the signal.
SBW RST	Spy-Bi-Wire emulation: SBWTDIO data signal. This pin also functions as the RST signal (active low).
SBW TST	Spy-Bi-Wire emulation: SBWTCK clock signal. This pin also functions as the TST signal.
N/C	Not connected. Reserved.

### 2.2.8 Isolation Jumper Block: 3.3-V and 5-V Jumpers

The 5-V VBUS and 3.3-V power rails, which are sourced to the target from the emulator, travel through the isolation jumper block. This routing serves these functions:

- Measurement of the target power consumption
- Removing the emulator from the circuit when an external (non-USB) power source is used
- Removing the F5529 target from the circuit when a different external target board is attached to the emulator

Measuring the target power draw is as simple as removing the 3.3-V jumper and connecting an ammeter across it. The USB hub, emulator and dc-dc converter currents are then excluded from this measurement. However, anything that is connected on the F5529 LaunchPad development kit headers or power pins on the target domain below the dotted silkscreen line are included. If precise current measurement is needed, it is important to disconnect the backchannel UART and SBW lines in the jumper block as well.

See [Section 2.3](#) for more information about measuring power using these jumpers.

Sometimes you may want to use an external 3.3-V power source connected to the target power header pins. In this case, the 3.3-V jumper must be disconnected to avoid back-powering the emulator. See [Section 2.4](#) for more information on this procedure.

Otherwise, in normal operation, both these jumpers should be attached.

### 2.2.9 Isolation Jumper Block: Emulator Connection and Application UART

MSP430F5xx devices support both standard four-wire JTAG and the two-wire Spy-Bi-Wire (SBW) standard. The eZ-FET lite emulator on the F5529 LaunchPad development kit supports SBW only. These two signals travel through jumpers in the isolation block, and can be disconnected if desired. They are labeled on the block as "SBW RST" and "SBW TEST".

The backchannel UART consists of four signals: the data signals TXD and RXD, and the hardware flow control signals RTS and CTS. All four of these signals travel through the jumper block as well and can be disconnected.

Reasons to open these connections:

- When measuring current consumption, devices attached to I/O pins can consume power, influencing the measurement. Removing the jumpers prevents this.
- The backchannel UART pins can be configured for other functionality instead of the backchannel UART. If this is desired, it might be good to remove these jumpers, so that the emulator is not affected by any activity that your application presents on these signals. If only two general I/Os are needed and if hardware flow control is not needed, you might choose to remove only the hardware flow control (RTS and CTS) jumpers and leave the TXD and RXD jumpers in place.
- If you want to use the onboard eZ-FET lite emulator with a different target, you can remove the jumpers and connect your target hardware to the jumper block.

## 2.3 Measure Current Draw of MSP430 MCU

The following steps assume that the target F5529 is to be powered from the USB host, not from an external power source.

1. Remove the 3V3 jumper in the isolation jumper block. Attach an ammeter across this jumper.
2. Consider the effect that the backchannel UART and any circuitry attached to the F5529 may have on current draw. Maybe these should be disconnected, or their current sinking and sourcing capability at least considered in the final measurement.
3. Make sure there are no floating input I/Os. These cause unnecessary extra current draw. Every I/O should either be driven out or, if an input, should be pulled or driven to a high or low level.
4. Begin target F5529 execution.
5. Measure the current. (Keep in mind that if the current levels are fluctuating, it may be difficult to get a stable measurement. It is easier to measure quiescent states.)

This measurement does not include USB current, which is sourced through the 5V jumper instead. USB current levels can vary widely, depending on whether the connection is active or suspended, how much bus activity is happening, how long the cable is, and other factors.

If you are trying to achieve the LPM3 values shown in the F5529 data sheet and are having trouble, download the [F5529 code examples](#) and see MSP430F552x\_LPM3\_01.c, adjusting the I/O settings for your application.

## 2.4 Using an External Power Source

The F5529 LaunchPad development kit target device can be used with a power source other than USB. However, this should be done carefully to ensure proper system behavior. External power can be supplied by many sources, most commonly a direct power supply, or through a battery BoosterPack plug-in module.

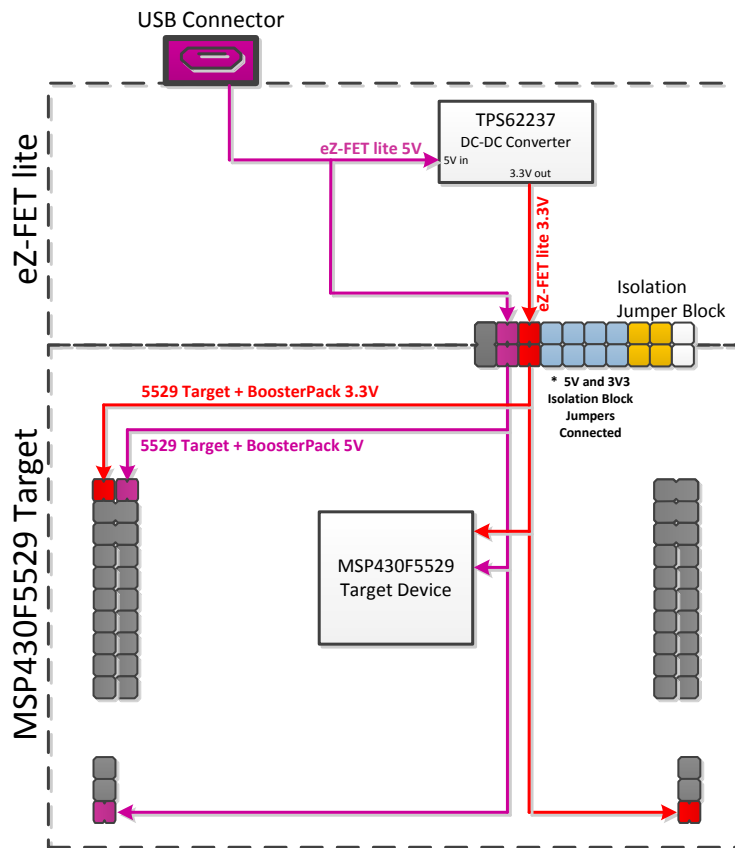

Figure 17. Power Block Diagram for Default Configuration With USB Power Only



### 2.4.2 External 5-V Power Source Without USB Connection

If USB connection is not required, the 5V jumper in the isolation jumper block may be left populated (see [Figure 19](#)). In this case, 3.3 V is derived through the dc-dc converter and, depending on the 3V3 jumper setting in the isolation jumper block, can power the target device as well. If using external power source for both 3.3 V and 5 V, consider recommendations for each.

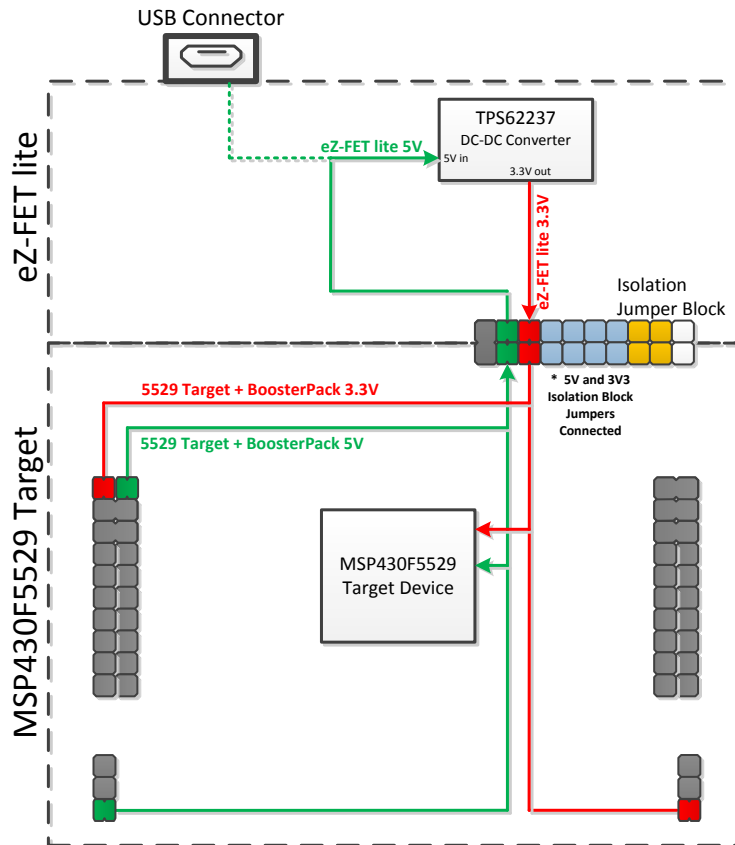

Figure 19. Power Block Diagram for External 5-V Power Source Without USB Connection

### 2.4.3 External 5-V Power Source With USB Connection

In certain situations, it is advantageous to have an external 5-V source and USB connected simultaneously (see Figure 20). The USB connection may be needed for direct USB communication, back-channel UART, or to allow for programming through emulation. In this scenario, the 5V jumper in the isolation block must be disconnected to allow for the two separate 5-V sources. If using external power source for both 3.3 V and 5 V, consider recommendations for each.

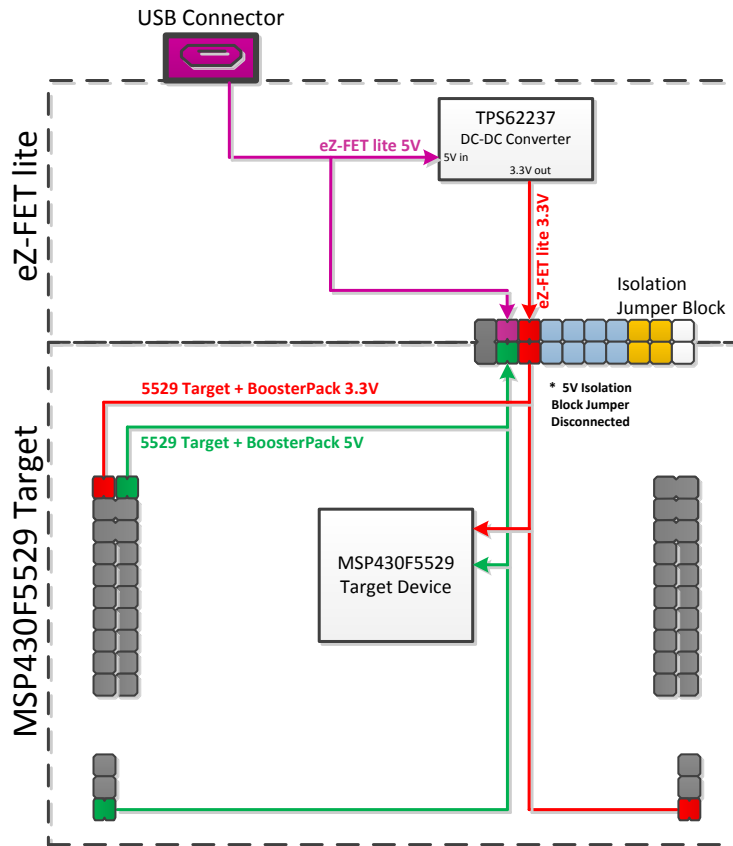

Figure 20. Power Block Diagram for External 5-V Power Source With USB Connection

## 2.5 Using the eZ-FET lite Emulator With a Different Target

The eZ-FET lite emulator on the F5529 LaunchPad development kit can interface to most MSP430 MCUs, not just the onboard F5529 target device.

To do this, disconnect every jumper in the isolation jumper block. This is necessary because the emulator cannot connect to more than one target at a time over the Spy-Bi-Wire (SBW) connection.

Next, make sure the target board has proper connections for Spy-Bi-Wire. To be compatible with SBW, the capacitor on RST/SBWDIO cannot be greater than 2.2 nF. The documentation for designing MSP430 JTAG interface circuitry is the [MSP430 Hardware Tools User's Guide](#).

Finally, wire together these signals from the emulator side of the isolation jumper block to the target hardware:

- 3.3 V
- GND
- 5 V (if needed)
- SBWDIO
- SBWTCK
- TXD (if the UART backchannel is to be used)
- RXD (if the UART backchannel is to be used)
- CTS (if hardware flow control is to be used)
- RTS (if hardware flow control is to be used)

This wiring can be done either with jumper wires or by designing the board with a connector that plugs into the isolation jumper block.

## 2.6 USB BSL Button

Like the vast majority of MSP430 MCUs, the F5529 has an on-chip bootloader (BSL). The BSL is a program that resides in a special protected location in the MCU flash memory and facilitates communication with an external host. Like tools with JTAG access, it can read and write the MCU flash memory. But unlike JTAG tools, it cannot be used to emulate code.

The interface to the BSL is often a UART or sometimes I2C. On USB-equipped derivatives, the BSL interface is USB.

In situations where JTAG access is not available, the BSL plays an important role in accessing the device. For example, it can be used to recover the device when something has corrupted internal flash. It is often used for products in the field, when there is no JTAG access. Because of the use in the field, the BSL is password-protected, which prevents unwanted access to proprietary application software. To serve its role in updating MSP430 flash memory, the BSL must be *invoked*, meaning that execution must be transferred to it. This can happen a few different ways, but on the USB BSL, one way is to pull the PUR pin high immediately after a BOR reset.

The USB BSL button on the F5529 LaunchPad development kit (see [Figure 21](#)) serves this purpose.

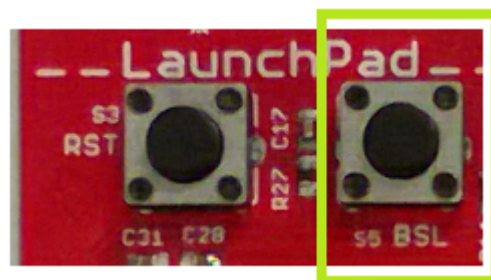
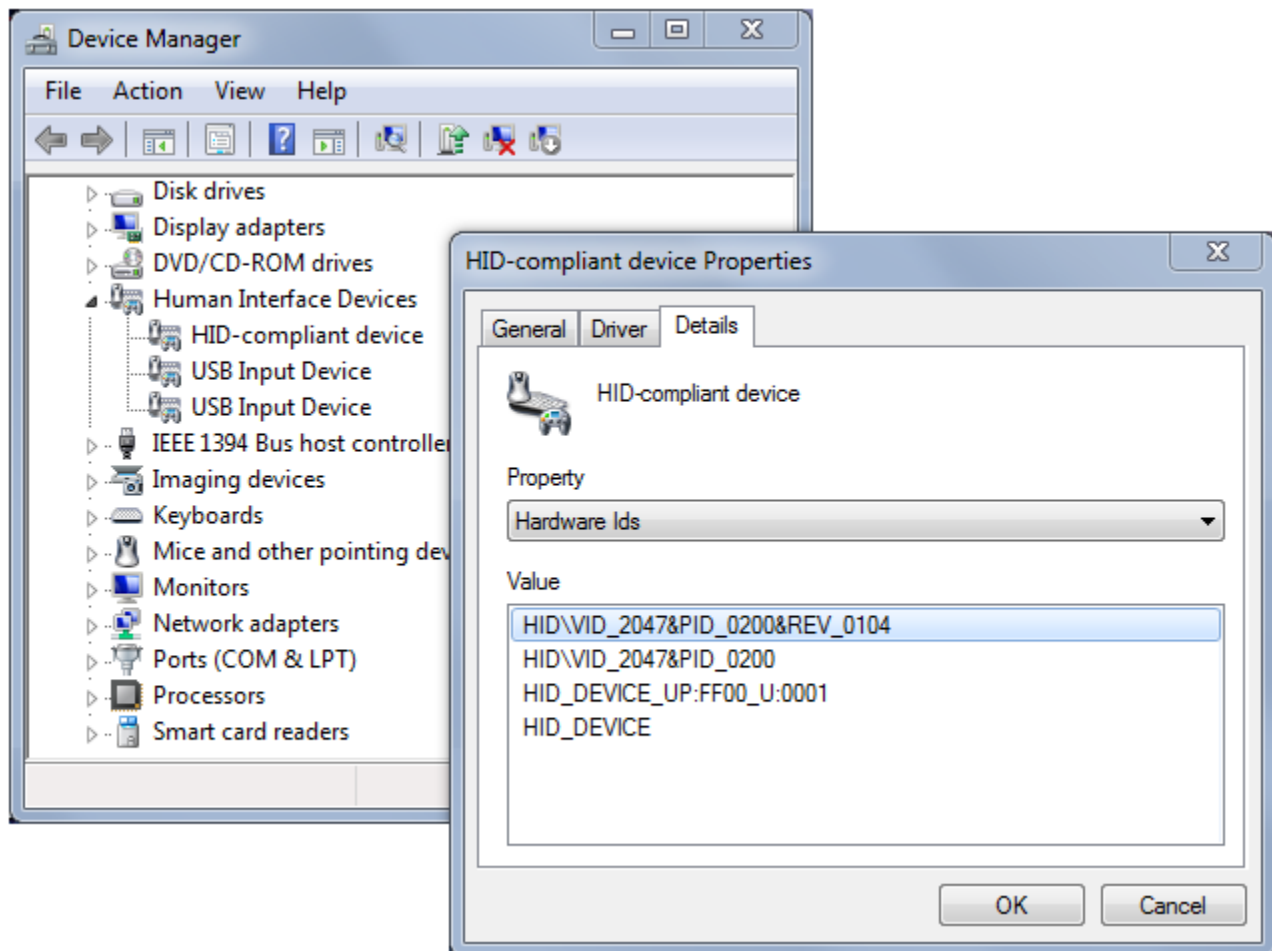

**Figure 21. USB BSL Button**

Hold the button down while attaching the F5529 LaunchPad development kit to the USB host, continue to hold it for approximately one second after attaching, and then release. (This assumes the F5529 LaunchPad development kit was unpowered prior to attaching, which allows a power-up event to occur.) The target F5529 should enumerate under USB BSL control as a HID interface. The USB BSL has its own *vendor ID* (VID) and *product ID* (PID), the codes used in USB to separate one USB product from another. The BSL VID and PID pair is 0x2047 and 0x0200.

In Device Manager, the HID interface can be found under the "Human Interface Devices" group. (See [Section 3.7](#) for instructions on starting Device Manager.) If you open Device Manager prior to attaching the LaunchPad development kit as described above, you will see it refresh, and then two new entries appear: "HID-compliant device" and "USB Input Device". Both refer to the one HID interface presented by the USB BSL.

These are generic names that can also appear for other HID devices. To be completely sure these entries derive from the USB BSL, you can look for the VID and PID associated with them, and make sure they are 0x2047 and 0x0200. For every such entry under the "Human Interface Devices" group, right-click on the entry, then click Properties, then go to the "Details" tab, and select "Hardware IDs" from the pulldown menu (see [Figure 22](#)).



**Figure 22. Identifying the USB BSL HID Interface in Device Manager**

For every other HID interface entry, the IDs in the "Value" field are different. For the USB BSL, they include the strings "VID\_2047" and "PID\_0200".

If these interface entries do not appear, then something went wrong in the procedure to press the USB BSL button to invoke the BSL. Retry the procedure.



After this interface enumerates, a host application is needed to interface with it and issue BSL commands to access the firmware on the MSP430 MCU. The [MSP430 USB Developers Package](#) includes a firmware updater application that uses the USB BSL to download programs. For its input, it uses TI-TXT object-code files. TI-TXT is a simple text-based object-code format that used with MSP430 MCUs to store and distribute compiled code. These files can be generated by CCS or IAR. TI-TXT files for the software examples are included in the zip file (`\bin\simpleBackchannel.txt` and `\bin\emulStorageKeyboard.txt`).

See the application report [USB Field Firmware Updates on MSP430 MCUs](#) for information about designing firmware update into your USB application. Additional information about the MSP430 BSL can be found in the [MSP430 Programming With the Bootloader \(BSL\)](#).

## 2.7 **BoosterPack Plug-in Module Pinout**

The F5529 LaunchPad development kit adheres to the 40-pin LaunchPad development kit pinout standard. A standard was created to aid compatibility between LaunchPad development kit and BoosterPack plug-in module tools across the TI ecosystem.

The 40-pin standard is backward-compatible with the 20-pin one used by other LaunchPad development kits like the MSP-EXP430G2. This allows 20-pin BoosterPack plug-in modules to be used with 40-pin LaunchPad development kits.

This having been said, while most BoosterPack plug-in modules are compliant with the standard, some are not. The F5529 LaunchPad development kit is compatible with all 20-pin (and 40-pin) BoosterPack plug-in modules *that are compliant with the standard*. If the reseller or owner of the BoosterPack plug-in module does not explicitly indicate compatibility with the F5529 LaunchPad development kit, you might want to compare the schematic of the candidate BoosterPack plug-in module with the LaunchPad development kit to ensure compatibility. Keep in mind that sometimes conflicts can be resolved by changing the F5529 device pin function configuration in software. More information about compatibility might also be found at <http://www.ti.com/launchpad>.

[Figure 23](#) shows the 40-pin pinout of the F5529 LaunchPad development kit.

Software configuration of the pin functions plays a role in compatibility. The F5529 LaunchPad development kit side of the dashed line shows all of the functions for which the F5529 device pins can be configured. This can also be seen in the [MSP430F5529 data sheet](#). The BoosterPack plug-in module side of the dashed line shows the standard. The F5529 function whose color matches the BoosterPack plug-in module function shows the specific software-configurable function by which the F5529 LaunchPad development kit adheres to the standard.

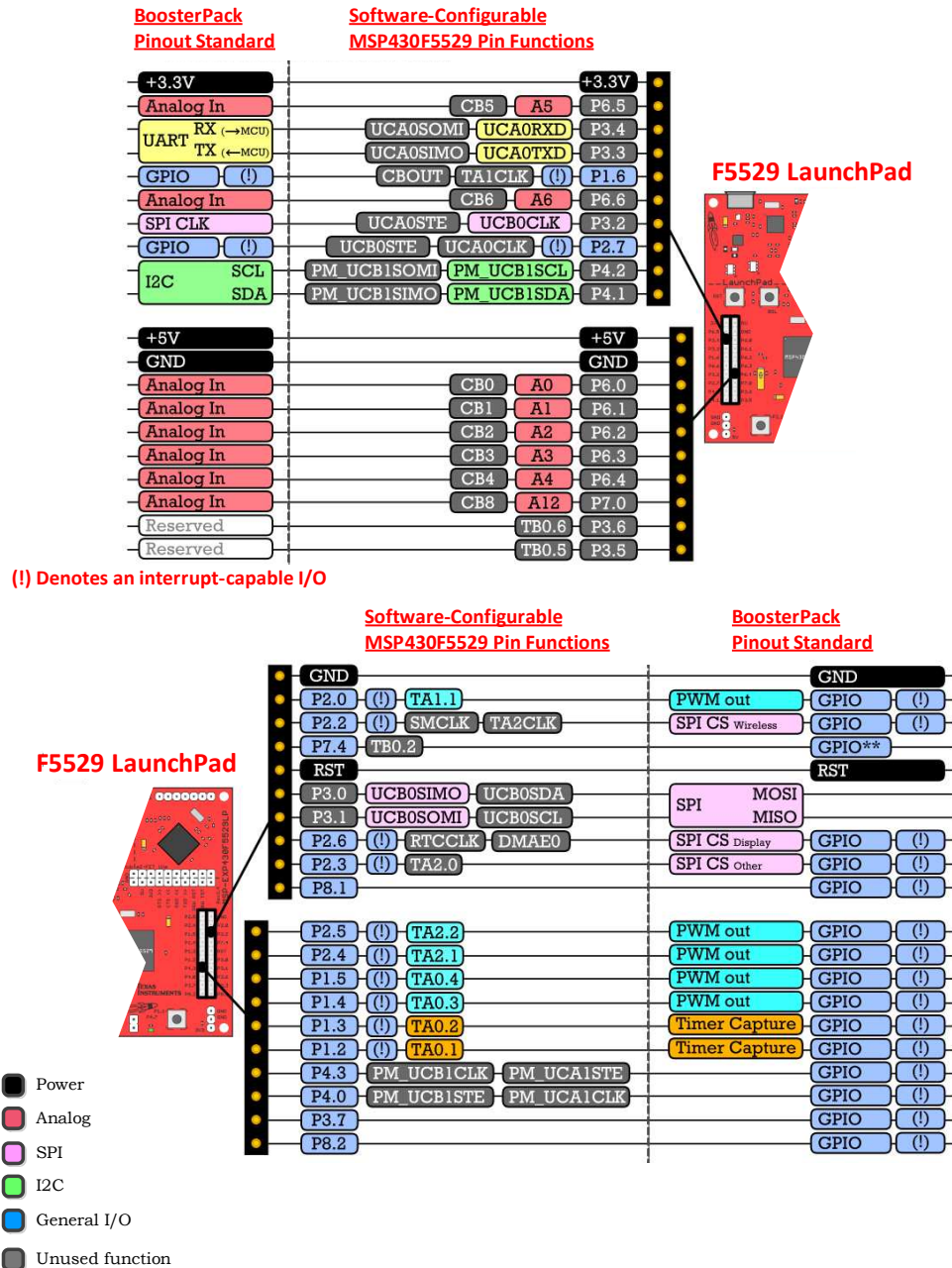

Figure 23. F5529 LaunchPad Development Kit to BoosterPack Plug-in Module Connector Pinout

## 2.8 Design Files

A complete schematic is available in [Section 6](#). All hardware design files including schematics, layout, bill of materials (BOM), and Gerber files are in the [MSP-EXP430F5529LP Hardware Design Files](#). The software examples are available in the [MSP-EXP430F5529LP Software Examples](#). More information about the software is available in [Section 3](#).

The schematic PDF is searchable to make it easier to follow signals across the multipage schematic.

## 2.9 Hardware Change Log

[Table 4](#) lists the changes to the MSP-EXP430F5529LP hardware.

**Table 4. Hardware Change Log**

PCB Revision	Description
Rev 1.4	Initial release
Rev 1.5	Removed TPS2041B power switches. Changed to sturdier BoosterPack plug-in module male header pins
Rev 1.6	Updated some pad dimensions for manufacturing. Changed mounting holes to 125 mil.
Rev 1.7	Changed Q2 crystal to X1A0001410014. Updated rear silkscreen to current LaunchPad development kit standards. Added CE marking to silkscreen.

### 3 Software Examples

The software examples, including TI-TXT object-code firmware images, are available in the [MSP-EXP430F5529LP Software Examples](#). There are two software examples included with the F5529 LaunchPad development kit, as shown in [Table 5](#).

**Table 5. Software Examples**

Demo Name	USB Interface Type	Description	Described In...
emulStorageKeyboard	MSC: in-flash storage volume HID: emulated keyboard	The out-of-box demo that is programmed on the F5529 LaunchPad development kit from the factory. Its function is described in <a href="#">Section 1.3</a> . Demonstrates a more advanced USB device than simpleUsbBackchannel.	<a href="#">Section 3.5</a>
simpleUsbBackchannel	CDC: Virtual COM Port (or, optionally, HID-Datapipe)	A very simple example showing how to send and receive data on both a virtual COM port USB connection and the backchannel UART	<a href="#">Section 3.6</a>

The backchannel code in simpleUsbBackchannel is implemented as a simple library that can be copied into any code project in which backchannel access is needed.

#### 3.1 MSP430 Software Libraries: driverlib and the USB API

The examples are built upon two MSP430 libraries available from TI:

- driverlib: A foundational MSP430 software library that is useful for interfacing with all MSP430 core functions and peripherals, especially clocks and power. driverlib is part of [MSP430Ware](#). The examples contain a subset of full driverlib.
- MSP430 USB API: Useful for quickly creating USB applications. The API is part of the [MSP430 USB Developers Package](#). The full USB API is included.

When you begin your own development, you will need more information about these libraries than can be included in this user's guide. All of the information that you need is in the downloads linked above. Each has its own documentation, and the USB Developers Package contains additional tools, 20+ more USB examples, and detailed documentation.

The emulStorageKeyboard example also uses an MSP430 port of the open-source FatFs file system software, which interacts with FAT storage volumes. It has been modified to work with internal MSP430 flash memory.

#### 3.2 Viewing the Code

Although the files can be viewed with any text editor, more can be done with the projects if they are opened with CCS or IAR. (Although support for mspgcc is increasing, the USB API does not yet fully support mspgcc. See the FAQs in [Section 5](#).)

CCS and IAR are each available in a full version and a free code-size-limited version. Although the software demo can be built with the free version of CCS, the code is too large to be built with the free version of IAR ([IAR KickStart](#)). This is primarily because the software demo has an MSC interface in it, and MSC interfaces and storage volumes require more memory. Most USB examples built on the MSP430 USB API (in the [MSP430 USB Developers Package](#)) that do not have an MSC Interface can be built with IAR KickStart, and IAR Embedded Workbench is fully supported.

See the [MSP430 software tools page](#) to download these IDEs and for instructions on installation.

### 3.2.1 CCS

CCS v5.4 or higher is required. When CCS has been launched, and a workspace directory chosen, click Project and then Import Existing CCS Eclipse Project. Browse to the desired demo project directory containing main.c. This is either simpleUsbBackchannel or emulStorageKeyboard (see [Figure 24](#)).

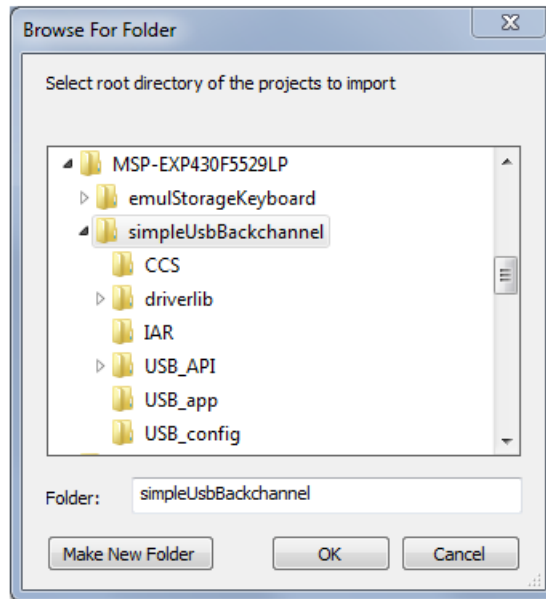

**Figure 24. Browse to Demo Project for Import Function**

Selecting the \CCS subdirectory also works. (The CCS-specific files are located there.)

Click OK, and CCS should recognize the project and allow you to import it. The indication that CCS has found it is that the project appears as shown in [Figure 25](#), and it has a checkmark to the left of it.

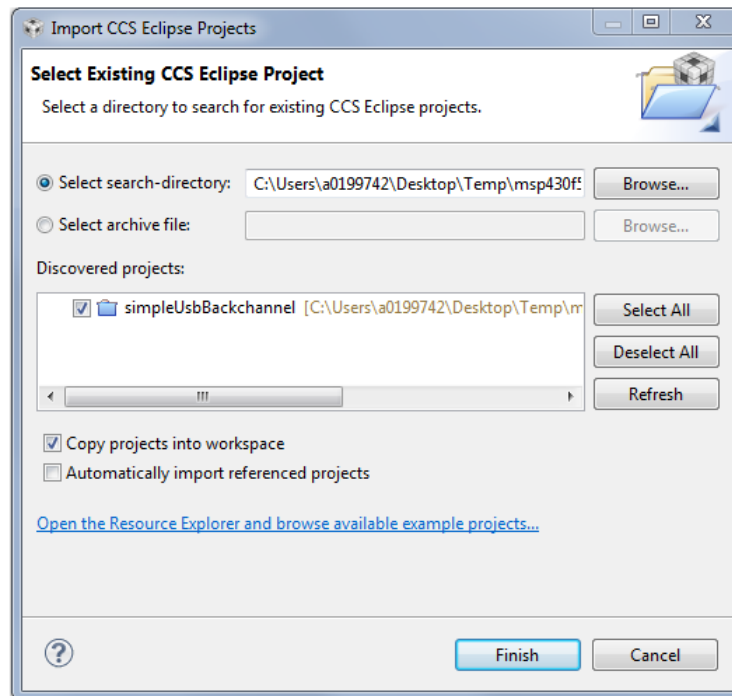

**Figure 25. When CCS Has Found the Project**

Sometimes CCS finds the project but does not have a checkmark; this might mean that a project by that name is already in the workspace. Rename or delete the existing project to resolve this conflict. (If you do not see the existing project in the CCS workspace, check the workspace directory on the file system.)

Finally, click Finish. Even if you check the "Copy projects into workspace" checkbox, most of the resources are linked and remain in their original location.

If using CCS v5.4, you may see a "#303-D typedef" warning. This warning should not cause problems, but see [Section 5](#) for more information and instructions to resolve it.

### 3.2.2 IAR

IAR v5.50 or higher is required. To open the demo in IAR, click File, then click Open, then click Workspace..., and browse to the \*.eww workspace file inside the \IAR directory of the desired demo. All workspace information is contained within this file.

The directory also has an \*.ewp project file. To open this file into an existing workspace, click Project, and then click Add-Existing-Project....

Although the software examples have all of the code required to run them, IAR users may want to download and install [MSP430Ware](#), which contains the full USB Developers Package, driverlib, and the TI Resource Explorer. These are already included in a CCS installation (unless the user selected otherwise).

### 3.3 Example Project Software Organization

The simpleUsbBackchannel example and the emulStorageKeyboard example share a similar project organization. [Figure 26](#) shows the CCS version of emulStorageKeyboard, and [Table 6](#) describes the functions of these files and directories.

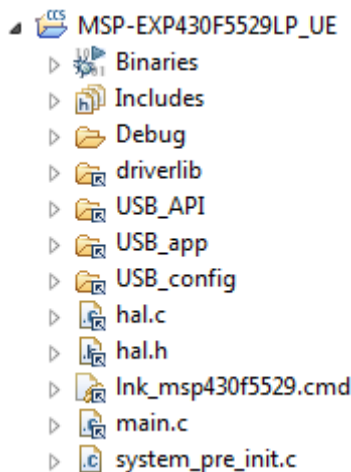

**Figure 26. F5529 LaunchPad Development Kit Demo Software Organization**

**Table 6. Demo Project File and Directory Descriptions**

Name	Description
main.c	The main() function
hal.c, hal.h	Hardware abstraction layer for the MSP430F5529 LaunchPad development kit
driverlib	MSP430 foundational software library, for accessing core MSP430 functions and peripherals. The USB API and examples use it to manage clocks, power, and the DMA module. driverlib is part of <a href="#">MSP430Ware</a> .
USB_API	The MSP430 USB API, part of the <a href="#">MSP430 USB Developers Package</a> .
USB_config	Contains three files that configure the USB API for the application needs. In particular, they define the USB interfaces that are used for the respective demo application. These files were generated by the USB Descriptor Tool, located in the <a href="#">MSP430 USB Developers Package</a> .
USB_app	Files related to USB functionality, but which are part of the application and not the USB API itself. These files handle the keyboard emulation, and implement the virtual storage volume mounted by the device. The directory also contains the USB "event handlers".

### 3.4 USB Configuration Files

The USB configuration files, in the USB\_config directory, determine what USB interfaces the USB API presents to the USB host. These files are generated by the MSP430 USB Descriptor Tool.

The Descriptor Tool customizes the API USB interfaces and generates all of its USB descriptors (see [Figure 27](#)). (For a discussion on USB descriptors, see Step 2 of [Section 1.3](#).) For example, with just a few clicks, the Tool can create a composite USB device with three virtual COM ports and an emulated mouse.

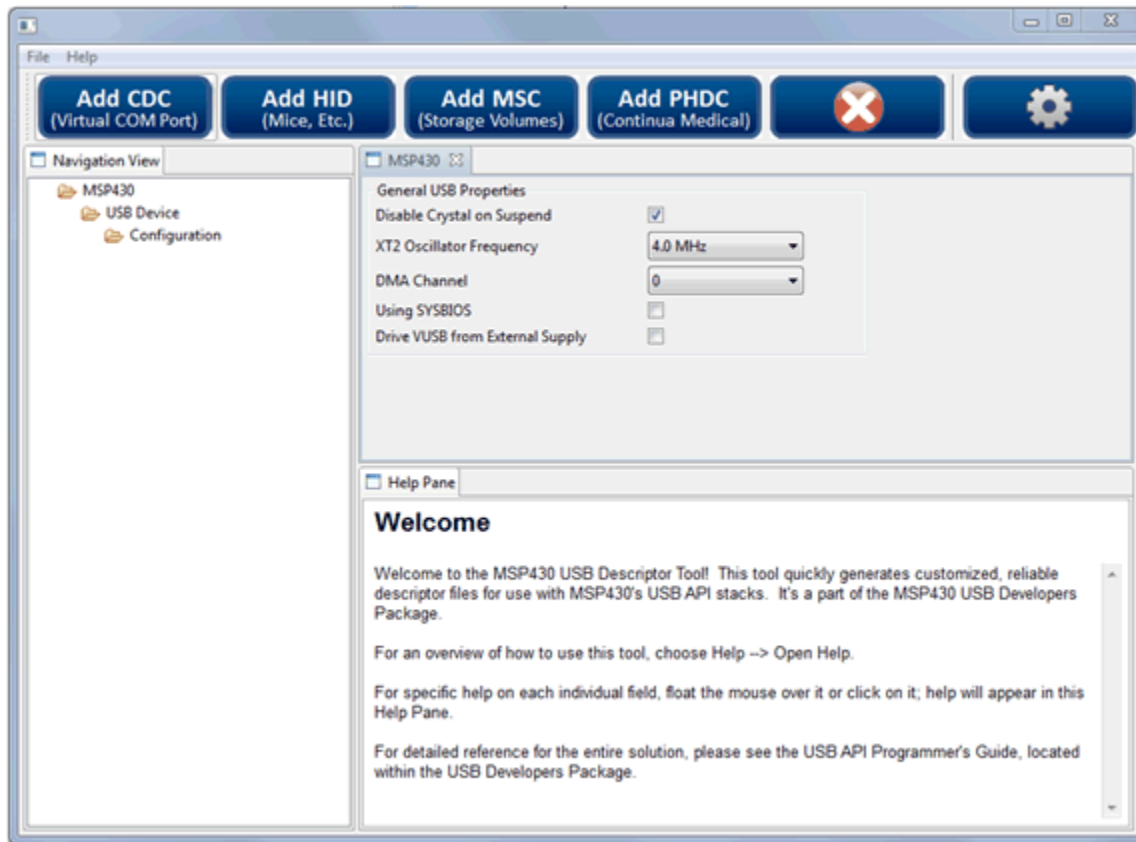

**Figure 27. MSP430 USB Descriptor Tool**

For the simpleUsbBackchannel demo, these files cause the API to present a single CDC interface. An application can then be written to simply send and receive data over that interface.

For the emulStorageKeyboard example, these files cause the API to have an MSC interface and an HID interface. They also cause that HID interface to be a keyboard. The application is then responsible for accessing the storage volume for the MSC interface and for sending HID "reports" that contain key press data.

\*.dat input files for the Descriptor Tool are located inside each example project directory. This allows easy regeneration of the output.

### 3.5 Out-of-Box Experience: *emulStorageKeyboard*

This is the demo that is loaded into the F5529 LaunchPad development kit at the factory. It is described in [Section 1.3](#). This demo is slightly more advanced than the *simpleUsbBackchannel* demo.

The code is prolifically commented, and the following sections provide additional detail.

#### 3.5.1 Flowchart

Figure 28 shows the program flow. The following sections reference this flow.

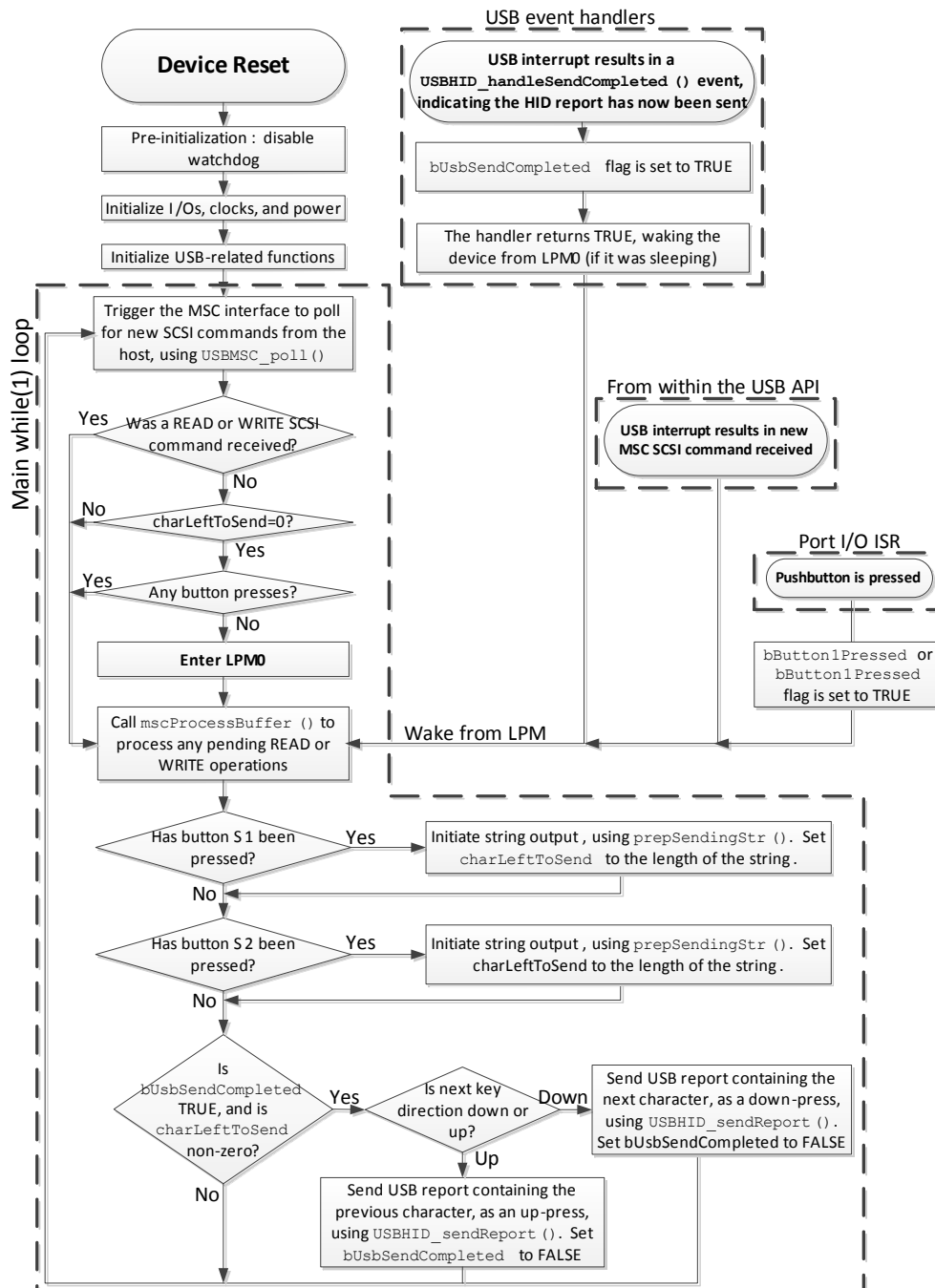

Figure 28. Demo Program Flow



### 3.5.2 Pre-Initialization

Pre-initialization refers to the activity that happens before the first line of main().

As described for the simpleUsbBackchannel example (see [Section 3.6.5.1](#)), it is often convenient during development to disable the watchdog at the beginning of execution. But for some application programs, including this demo, there's a twist. Programs that contain a large amount of allocated RAM may never reach the first line of main(). This is because the first line of execution of a C program is not actually the first line of main(); instead, the compiler inserts code prior to main that handles preparatory functions, like initializing variables.

So if the amount of allocated RAM is large enough, the time required to initialize it may exceed the watchdog's expiration time. To the developer, this appears as execution never quite arriving to the first line of main().

A solution to this is to define a pre-init function. In CCS, this is the function `_system_pre_init()`; in IAR, it is the function `__low_level_init()`. The developer can write code here that executes immediately after a reset, before RAM is initialized. When large amounts of RAM are allocated, it can be necessary to hold the watchdog here.

The F5529 LaunchPad development kit software demo does this. [Figure 29](#) shows the implementation of both the `system_pre_init.c` file in the project and the function inside it.

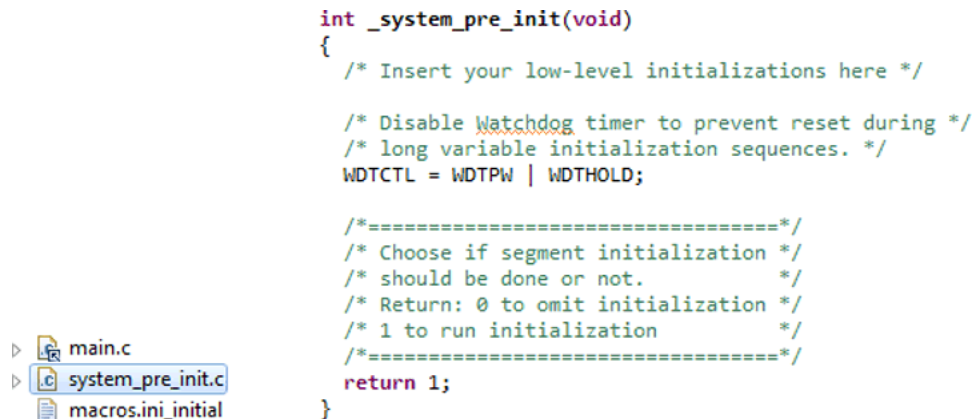

**Figure 29. Disable the Watchdog in Pre-Initialization**

### 3.5.3 Initialization

This demo uses driverlib somewhat more heavily than the simpleUsbBackchannel example does. driverlib is used for the initialization of clocks, power, and ports. The use of driverlib makes the code appear different in the two examples, but the same actions are being taken. See [Section 3.6.5](#) for more information on how to initialize these functions and initialize USB.

The following sections describe initialization that is unique to this example.

#### 3.5.3.1 Configuring the Keyboard

The keyboard function must be initialized before operation. Keyboard.c maintains a report structure that will later be sent by the USB API.

#### 3.5.3.2 Configuring the MSC Interface

The MSC interface also must be initialized. First, `initMscIntf()` obtains from the USB API a pointer to a structure that will later be used to exchange information about SCSI READ and WRITE commands. It also registers with the API the location of a RAM buffer that the application has allocated for the exchange of block data during READ and WRITE commands.

The application must also tell the USB API about the mass storage volume's media; for example, how big it is, if it is write protected, and if it is been changed recently (if removable). It does this with `USBMSC_updateMediaInfo()`.

### 3.5.4 Handling SCSI Commands

The first item in the main loop is a call to `USBMSC_poll()`.

```
__disable_interrupt();
if ((USBMSC_poll() == kUSBMSC_okToSleep) && !charLeftToSend &&
    !bButton1Pressed && !bButton2Pressed)
{
    __bis_SR_register(LPM0_bits + GIE);
}
__enable_interrupt();
```

Notice all of the code surrounding `USBMSC_poll()`; this is discussed in [Section 3.5.5](#).

Every USB application with an MSC interface must call this function regularly to check for any SCSI commands received from the host. The USB MSC interface is essentially a carrier for the same SCSI commands used with many non-USB storage devices that are commonly used with computers. In other words, the interface is essentially "SCSI-over-USB".

`USBMSC_poll()` automatically handles all SCSI commands except READ and WRITE. These two require media access. The developer might choose among a wide variety of media types, and there are many different file system "middleware" offerings on the market. To preserve these options for the developer, the MSC API lets the application access the media. `mscProcessBuffer()` is the function that serves this function for the software demo; it receives a block buffer from the API and exchanges data between this buffer and the media (see [Section 3.5.7](#) for more information).

Most MSC applications need this exact same block within the main loop, except that the checking of the `charLeftToSend` and `button-pressed` flags are specific to this demo application.

### 3.5.5 LPM0 Entry

Developing low-power applications is not just about finding the MCU with the lowest-current low-power modes, although that is an important step. The software also must be written to effectively control the circuitry and make good use of the low-power modes that are available.

In an application based on a main loop, one way to do this is to have a single location in the loop where a low-power mode is conditionally entered. Various events can wake it from this sleep and allow the main loop to resume execution, check flags, and handle any waiting events, and then eventually loop back and sleep again.

The primary low-power modes for MSP430 MCUs are LPM0, LPM3, and LPM4 (see [Table 9](#) for a brief description of these modes). Lower numbers represent "lighter" sleep, while higher numbers generally mean "heavier" sleep. When the MCU is not in an LPM mode, it is considered to be in "active mode", which means that all clocks are enabled and the CPU is executing code. (See the MSP430 family user's guides for complete descriptions of these modes.)

The developer's choice of low-power mode is based on what functionality the MCU needs to keep alive while sleeping. In the case of USB, the MSP430 can enter LPM0 while the USB connection is active (not suspended by the USB host), but this is the deepest possible sleep state. When suspended, it can go into LPM3, which is significantly lower power than LPM0.

With this in mind, refer back to the flowchart in [Figure 28](#). The main loop begins by trying to enter LPM0, but to do so it evaluates several conditions: the return value of `USBMSC_poll()`, the number of characters waiting to be typed to the host, and whether a LaunchPad development kit pushbutton has been pressed. This code was shown in the previous section.

If `USBMSC_poll()` returns `kUSBMSC_processbuffer`, it means the API is waiting for the application to finish the READ or WRITE operation, and thus it is important to skip LPM0 and proceed to `mscProcessBuffer()`.

Similarly, code checks for these other interrupt-driven events that may have occurred after the main loop checked their flags. If execution enters sleep while these flags are set, they are not handled until yet another interrupt occurs. This could cause the device to be unresponsive.

For similar reasons, interrupts are disabled prior to evaluating any of these flags. It takes several cycles to evaluate these conditions, and because these events can occur at any time, the status of the early flags could potentially change before LPM0 is actually entered. If LPM0 were then entered, they would get missed. Disabling interrupts prevents that from happening; the events are simply queued up. When interrupts are reenabled, any interrupts that came in take effect immediately.

Therefore, the code simultaneously enters LPM0 and reenables interrupts by setting the GIE bit:

```
_bis_SR_register(LPM0_bits + GIE);
```

If an interrupt had come in while interrupts were disabled, the CPU will wake again in the very next cycle after entry.

### 3.5.6 LPM0 Exit

When emulating the code, if the device is sleeping, main() execution is seen resting at the LPM0 entry. The demo application can then exit LPM0 and resume execution in response to three different events:

- A SCSI READ/WRITE command has been received. (This happens from a USB interrupt, which can happen at any time.)
- A USB event has occurred. (This happens from the USB event handlers, which are triggered by USB interrupts, which again can happen at any time.)
- One of the LaunchPad development kit pushbuttons has been pressed.

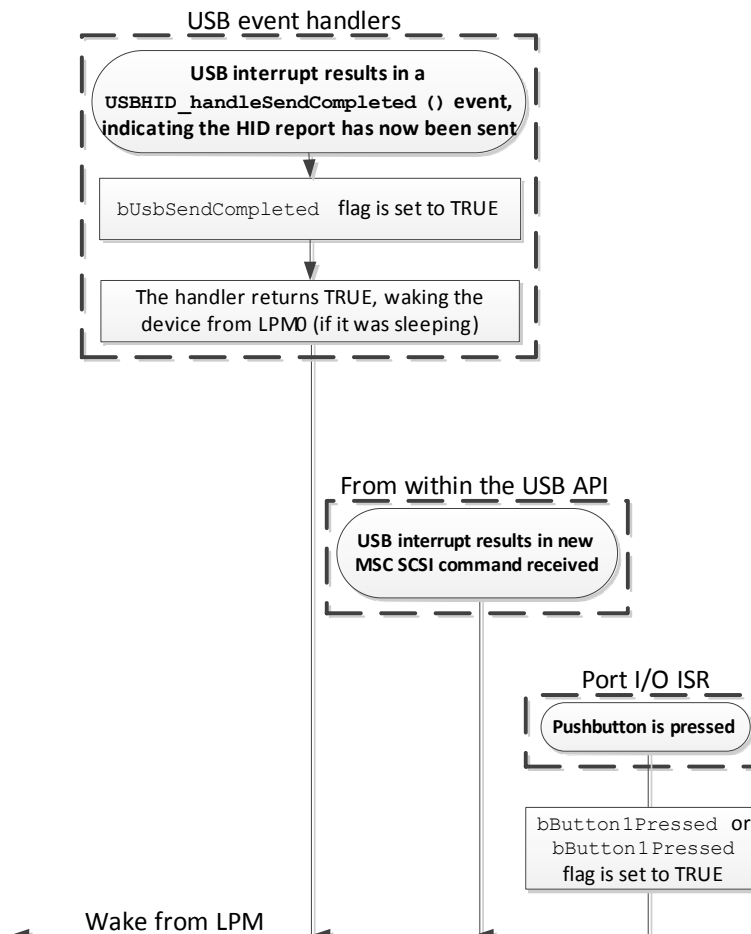

Figure 30. Waking From LPM0

USB events are like software callbacks, functions called by the USB interrupt service routine (ISR) that the application can choose to service. These handlers are in the file `usbEventHandling.c`. If the event handler returns `TRUE`, the CPU remains awake after the USB ISR returns; this causes execution to resume from the point of LPM0 entry, if it had been sleeping there. (If it had not been sleeping, then the resumption has no effect.)

The last event that can wake the CPU out of LPM0 is a pushbutton press. This generates an I/O port interrupt, and the port ISR in `hal.c` is executed. It includes an intrinsic function `__bic_SR_register_on_exit(LPM3_bits)`; this causes execution to resume from the point of LPM0 entry, if it had been sleeping there. Again, if it had not been sleeping, this resumption has no effect.

### 3.5.7 Emulated Storage Volume

`mscProcessBuffer()` is the first function to run after waking from LPM0. It checks the "operation" field of the `RWbuf_info` structure to see if the USB API is waiting for the application to handle any READ or WRITE buffer operations from the USB host.

If a READ or WRITE is pending, `mscProcessBuffer` accesses the media to perform the read or write. It does this by issuing low-level commands to the FatFs file system library, `disk_read()` and `disk_write()`.

The block of code within `mscProcessBuffer()` for performing reads is:

```
while (RWbuf_info->operation == kUSBMSC_READ)
{
    RWbuf_info->returnCode = disk_read(0,
        RWbuf_info->bufferAddr,
        RWbuf_info->lba,
        RWbuf_info->lbCount); // Fetch a block from the medium
    USBMSC_bufferProcessed(); // Close the buffer operation
}
```

In a more typical mass storage application, the media would probably be an SD-card or external SPI flash. In this application, the media is located inside the MSP430 internal flash memory. This is only approximately 60KB, but it is big enough for what this demo needs, and saves the cost and complexity of external media.

FatFs is commonly used to interface with FAT-formatted memory cards, but for this example it is been customized for internal MSP430 flash. Most of this was done in `disk_read()` and `disk_write()`.

Whereas the high-level FatFs calls ask FatFs to open or read files, and leave it to FatFs to parse the volume and locate the files itself, the low-level calls bypass this, asking FatFs to read/write specific locations in the volume. These locations are measured in *blocks* or *sectors*. The address of a block is called a *logical block address*, or *LBA*, which is a parameter passed to `disk_read()`.

The demo application implements the volume as an array called `storageVol[]`. The C-code contents of `storageVol[]` contain the files that were seen in Step 3 of [Section 1.3](#). `storageVol[]` occupies all of the F5529 upper on-chip flash memory, from address 0x10000 to the end of the map, 0x243FF. To ensure the linker does not place any code or other data there, a special linker segment has been set up: MYDRIVE. This segment is defined in the auxiliary linker file `\USB_app\F5529LP_UE.cmd`. `storageVolume.c` then contains code to locate `storageVol[]` there.

The volume within `storageVol[]` is formatted as FAT. It was generated using a procedure that is described in the comments in `storageVol.c`. You can use this same procedure to create your own storage volumes represented in C code, with your own file/directory sets.

If you are interested in using FatFs for SD cards, download the USB Developers Package and look in the USB examples for MSC interfaces. One of the examples is a USB SD-card reader, written to run on the F5529 Experimenter's Board ([MSP-EXP430F5529](#)) which has an SD-card socket on it. This example has a version of FatFs set up for this purpose.

### 3.5.8 Sending Data as a USB Keyboard

In USB, keyboards are implemented as Human Interface Device (HID) interfaces. Within the USB descriptors reported to the host during enumeration, the application declares itself to contain a keyboard HID interface. It then sends specially formatted HID reports to the host, to tell it about key presses. While no key presses occur, no reports are sent.

Although the word "send" is an easy way to describe it, it is not quite correct. In USB, everything is initiated by the host. What actually happens with HID interfaces is that the USB device prepares a report and makes it available to the host. Then, on a regular interval, the host polls the device to see if it has any reports ready. In the Descriptor Tool, this particular interface was set to have the fastest possible polling interval: 1 ms.

After receiving a report indicating a keystroke, the host assumes the key is held down until a report is later sent to indicate its release. Because of this, the demo application quickly follows every key-press report with a key-release report.

So when a LaunchPad development kit pushbutton press occurs, it sets a flag and wakes main(), had it been sleeping in LPM0. Execution eventually checks the flags associated with the buttons. If the button had been pressed, it calls prepSendingStr() to fetch the target string from the file associated with that button.

```
// Handle a press of button 1, if it happened
if (bButton1Pressed && !charLeftToSend)
{
    prepSendingStr("0:Button1.txt");
    bButton1Pressed = FALSE;
}
```

It uses high-level FatFs calls to do this – to mount the volume, open it, read it, and close it. When the string has been obtained, main() assigns the length of that string to charLeftToSend. While this variable is non-zero, it means there are still characters left to transmit to the host.

Later in main(), code evaluates charLeftToSend, and also checks whether a USB report is still waiting to be fetched from the host. If characters still need to be sent, and if the USB HID interface is available, the report is prepared, and USBHID\_sendReport() is called to "send" it. A flag bKeyDirIsDown is used to alternate between down-presses and up-presses, to ensure every down-press is followed by an up-press.

```
if (bUsbSendComplete && charLeftToSend)
{
    if(bKeyDirIsDown)           // Will this be a down-press?
    {
        KB_addKeyPressToReport(btnStr[btnStrLen-charLeftToSend]);
        bKeyDirIsDown = FALSE;
    }
    else                       // Or will it be an up-press?
    {
        KB_addKeyReleaseToReport(btnStr[btnStrLen-charLeftToSend]);
        bKeyDirIsDown = TRUE;
        charLeftToSend--;
    }
    bUsbSendComplete = FALSE;
    USBHID_sendReport(KB_getReportPtr(), HID0_INTFNUM);
}
```

USBHID\_sendReport() copies the report to the USB endpoint buffer, making it available to the host. HID0\_INTFNUM is a value that references this particular HID interface; if additional HID interfaces had been created within this device, this parameter is how code could access them separately. The Descriptor Tool defines an INTFNUM constant for every interface it creates, stored in descriptors.h.

When the host gets around to fetching the report, a USBHID\_handleSendCompleted() event is generated.

```
BYTE USBHID_handleSendCompleted (BYTE intfNum)
{
    bUsbSendComplete = TRUE;
    return (TRUE);    // Returning TRUE wakes the main loop, if it had been
                    // sleeping.
}
```

This is one of the USB event handlers in usbEventHandling.c. These handlers are defined by the API, and the developer can insert code that should execute when those events occur. In this application, the bUsbSendComplete flag is set to TRUE in the handler, and the handler returns TRUE, which wakes main() if it had been sleeping at the LPM0 entry. This allows main() to send the next character, if one is waiting to be sent.

### 3.5.9 Properly Handling USB Unplug Events

In USB, it is important to consider that the bus may suddenly become unavailable. For example, the USB cable can be removed by the user at any time. If the developer does not keep this in mind, it is easy to write code that can hang up indefinitely when it happens.

For example, suppose the `bUsbSendComplete` flag had been polled until it was set to `TRUE`. If the cable was then removed between the call to `USBHID_sendReport()` and the time the host fetches the report, the flag would never become `TRUE`, and execution would freeze. Granted, with a 1-ms polling interval, this is a very small window. But if this code went into a product, with thousands of users in the field, eventually it would occur. (The default LaunchPad development kit configuration is bus-powered, losing power when detached from the host. So this error won't occur unless external power is used. However, the code was written this way to show good USB coding practices.)

Another thing that can go wrong is if the host becomes unresponsive. This is more problematic for MSC and CDC interfaces than for HID interfaces, because the former use USB bulk transfers, which are more subject to host and bus conditions. In contrast, HID is guaranteed to be polled at the polling interval, as long as the host is functioning properly. But even so, if the host crashes, it is undesirable for the USB device to hang. Therefore, good coding practice requires considering what happens if the `USBHID_handleSendCompleted()` event never occurs, or if `USBHID_sendReport()` returns `kUSBHID_intfBusyError`.

The application deals with these problems by never depending on the `bUsbSendComplete` flag for execution fluidity. Whatever `USBHID_sendReport()` returns, the next line of code is always `USB_connectionState()`. So if the cable has been detached, execution shifts to the `switch()` case that shuts down all string sending and enters LPM3. If instead USB remains connected, but the host has crashed, then the application functions as it always had, with fluid execution; the only difference is that `USBHID_sendReport()` always returns `kUSBHID_intfBusyError` and no characters are actually sent.

### 3.5.10 Non-Maskable Interrupt (NMI) Vector

The MSP430 contains one vector that cannot be disabled by the general interrupt enable (GIE) bit: the NMI vector. Several different events are directed into the NMI vector, most of which involve critical functions. Oscillator failure is one example.

There is one NMI unique to USB operation: the "bus error", which is indicated when the `SYSUNIV` interrupt vector register contains the value `SYSUNIV_BUSIFG`. This involves the fact that the MSP430 USB module shares a block of RAM with the CPU, called "USB RAM". When the host suspends the USB module, it becomes clocked by a slow clock. If the CPU then tries to access USB RAM, the difference in clock speeds between this slow clock and the MCU clock creates a conflict, and recovery from the error is not possible without shutting down the USB module.

Fortunately this event is completely within control of software, by not accessing USB RAM during suspend. The USB API is written to not do this, and most applications do not have a reason to access USB RAM. Therefore, this error should never occur. But in the event that it does, the NMI is provided, and code is provided to handle the failure.

## 3.6 Example: *simpleUsbBackchannel*

The `simpleUsbBackchannel` example runs on Windows and Linux PCs. However, it does not run on Macs, because the OS X does not support composite CDC devices. This means that OS X does not support the eZ-FET lite emulator or its backchannel UART.

### 3.6.1 What It Does

The `simpleUsbBackchannel` example receives data over the backchannel UART and sends it back to the host PC over USB (see [Figure 31](#)). By default, the USB connection uses a CDC interface, which results in a virtual COM port on the host. Thus both sides of the communication loop terminate in virtual COM ports on the host. Through these COM ports, two instances of a terminal application can exchange data.

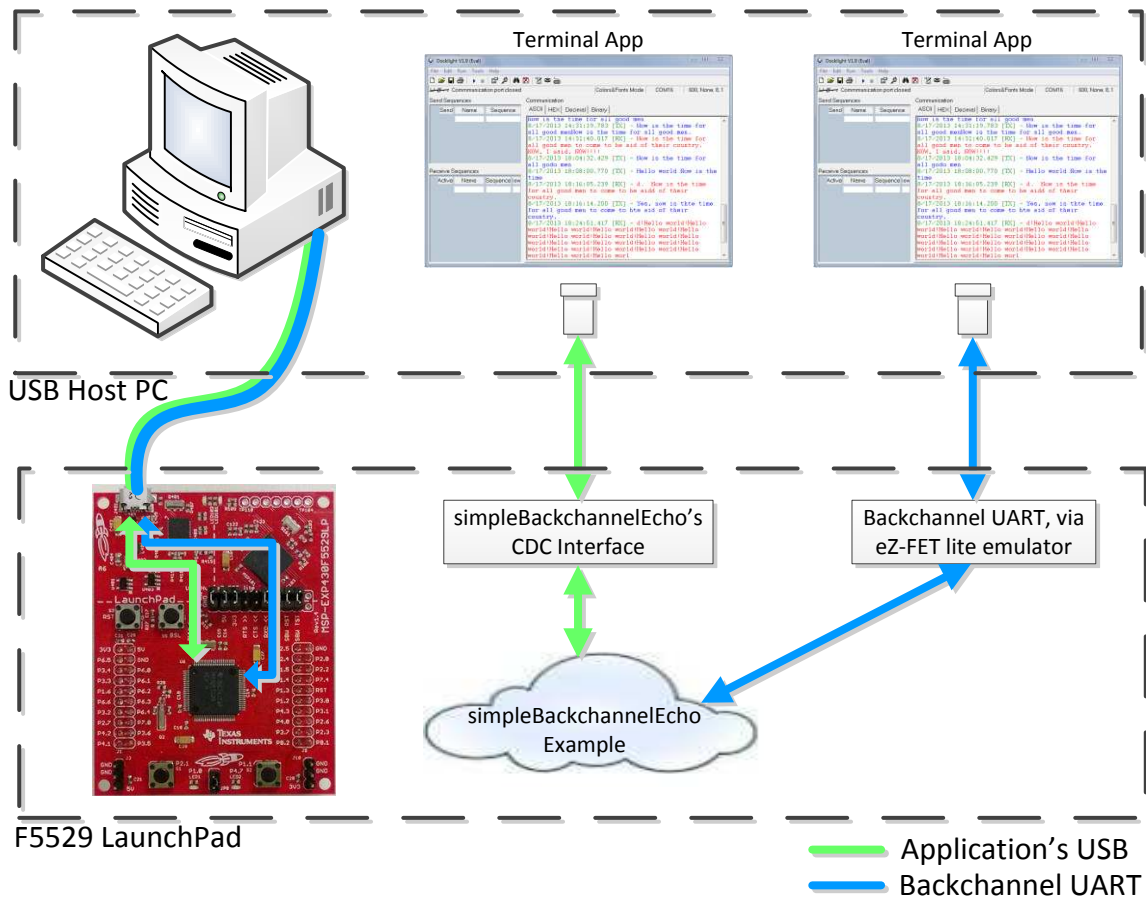

Figure 31. Movement of Data in simpleUsbBackchannel: CDC

### 3.6.2 Installing the CDC Interface

Now, build and run the example.

When you do this for the first time on a Windows PC, Windows asks for an INF file (simpleUsbBackchannel.inf) to associate with this device. This INF file is located in the simpleUsbBackchannel directory.

Windows XP starts an installation wizard when you attach the device; direct it to this INF file.

Windows 7 does not show a dialog box but, rather, indicates an installation failure in a bubble in the system tray. To install the device, open Device Manager (see Section 3.7). Locate the device (see Figure 32). Right-click on it, and click Update Driver Software.

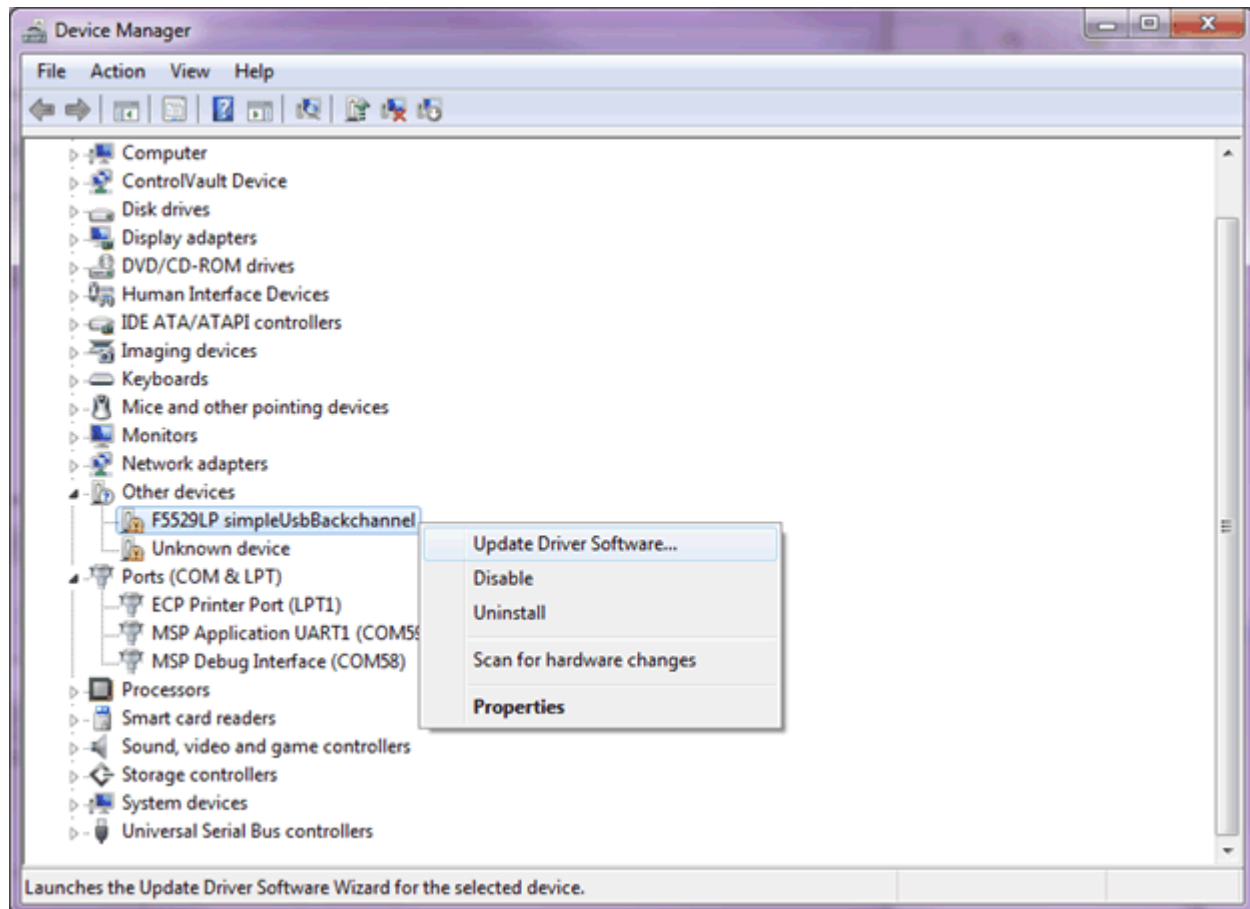

**Figure 32. simpleUsbBackchannel USB Virtual COM Port, Needing a Driver**

In the dialog box, browse to the INF file in the simpleUsbBackchannel directory.

If more help is needed to install the CDC interface, see the Examples Guide in the [MSP430 USB Developers Package](#), which contains a more complete description.

Linux PCs do not have this requirement. CDC interfaces enumerate silently as TTY devices in the `/dev` directory.



### 3.6.3 Operating the Example

When installation is complete, both COM ports are available. On a Windows PC, Device Manager runs (see [Figure 33](#)) (see [Section 3.7](#) for how to open Device Manager).

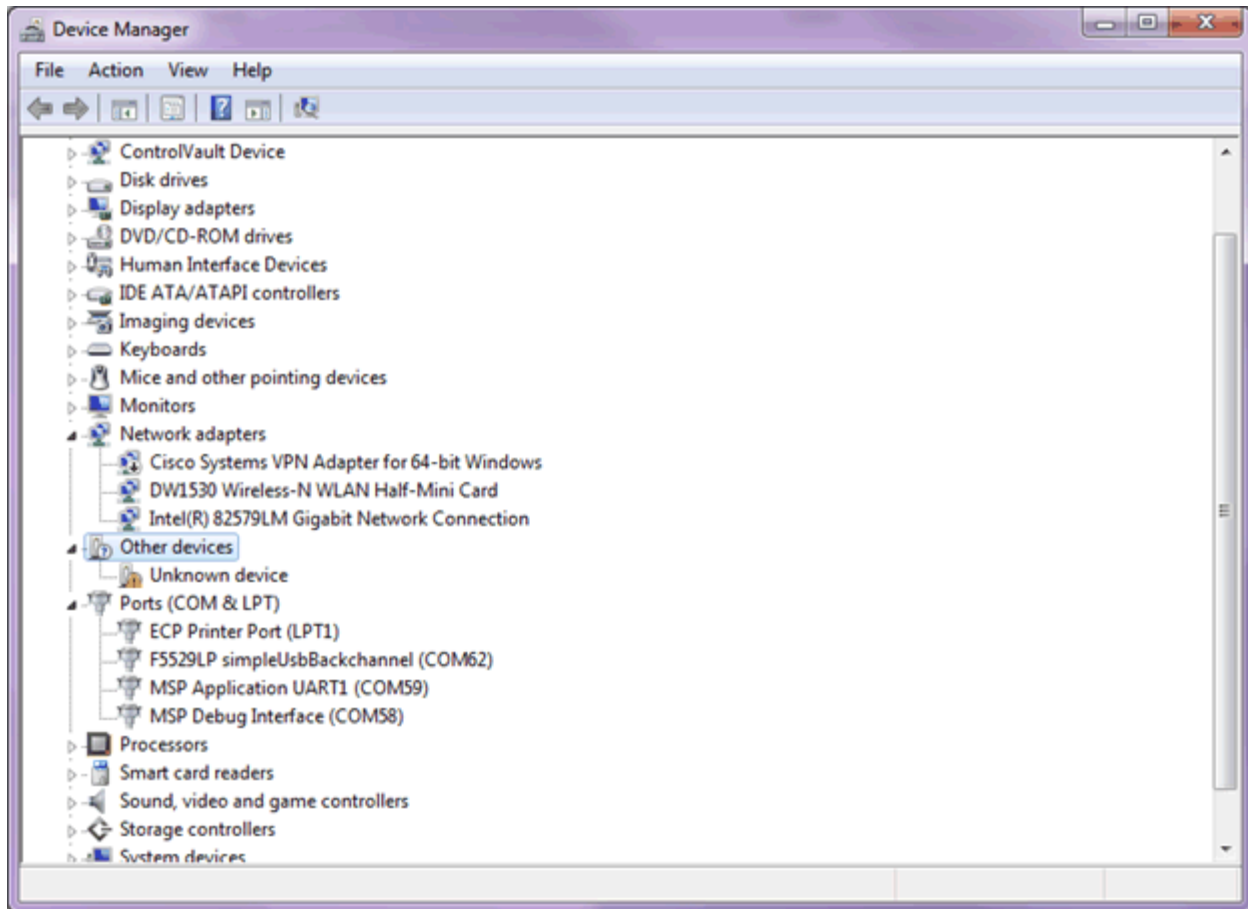

**Figure 33. Device Manager After Both Ports are Enumerated**

The UART backchannel port name is "MSP Application UART1". The USB CDC interface for the simpleUsbBackchannel application is "F5529LP simpleUsbBackchannel". The CDC interface port only appears when the simpleUsbBackchannel application is running, whereas the backchannel port is present anytime the F5529 LaunchPad development kit is physically connected.

The COM port numbers associated with each are shown in the Device Manager. Open two instances of a terminal application, like Hyperterminal or Docklight, and associate one with the backchannel and the other with the CDC interface. Make sure that the terminal settings in each terminal application disable flow control and have baud rate set to 28.8 kbps.

When both ports are open, enter data into one of the terminal applications. The data should appear in the other terminal application. The same should work in reverse.

### 3.6.4 Backchannel UART Library: bcUart.c, bcUart.h

This example includes a simple library for the backchannel UART, which can be copied into any project to use the backchannel. It can also be modified as needed. Copy bcUart.c and bcUart.h into the target project, and include the bcUart.h file from any files that access it.

The library is preconfigured to use SMCLK as the clock source, and for the speed of SMCLK to be 8 MHz. The baudrate is preconfigured for 28.8 kbps with no hardware flow control.

SMCLK is generally a good choice for the backchannel UART in a given application, but the clock speeds may change. Instructions for this are located in bcUart.h.

On the F5529 LaunchPad development kit, the backchannel UART is implemented with the USCI\_A1 module. The RTS and CTS flow control signals are implemented on the P6.7 and P1.7 I/O pins, respectively. All of these locations are hardwired on the F5529 LaunchPad development kit and are independent from the 40-pin BoosterPack plug-in module header.

Table 7 shows some constants in bcUart.h that define the library behavior.

**Table 7. Backchannel Library: Constants to Configure**

Constant	Description
UCA1_OS UCA1_BR0 UCA1_BR1 UCA1_BRS UCA1_BRF	Set the baudrate. Must be adjusted if SMCLK speed or baudrate are configured to anything other than 8 MHz and 28.8 kbps, respectively. See bcUart.h for instructions.
BC_USE_HW_FLOW_CONTROL	If hardware flow control is desired, un-comment this #define
BC_RXBUF_SIZE	Set the size of the buffer that receives data over the backchannel UART.
BC_RX_WAKE_THRESH	When this number of bytes have been received into the receive buffer, the bcUartRxThresholdReached flag is set to TRUE, and the main application is awakened from any LPM it might be in.

Table 8 shows the library function calls.

**Table 8. Backchannel Library: Functions**

Function	Description
void <b>bcUartInit</b> (void)	Call once during program initialization
void <b>bcUartSend</b> (uint8_t * buf, uint8_t len)	Send <i>len</i> bytes stored at <i>buf</i> over the UART.
uint16_t <b>bcUartReceiveBytesInBuffer</b> (uint8_t* buf)	Copy any bytes received into the library UART receive buffer into <i>buf</i> and return the number of bytes copied.
USCI_A1 Interrupt Vector	The library includes a definition of the USCI_A1 ISR, which copies incoming UART bytes into a receive buffer.

If the application uses the USCI\_A1 ISR for another purpose in addition to the backchannel, it is necessary to merge that operation with the backchannel library ISR.

### 3.6.5 Code Description: Initialization

First, the device must be initialized. Although called from main(), much of this initialization is defined within hal.c and hal.h. Most of the examples in the USB API v4.0 and later include this hardware abstraction layer (HAL) file to assist in running on multiple USB-equipped boards available from TI. Clocks, power, and port settings can be hardware-specific and, thus, are handled by the HAL. This demo follows that convention.

#### 3.6.5.1 Stopping the Watchdog

The MSP430 contains a watchdog timer that is enabled by default. After a reset, an MSP430 application has approximately 32 ms to either reconfigure the watchdog or put it on hold. Otherwise, the watchdog resets the MSP430 device.

Watchdogs are an important part of writing robust production-level code, but if you are only experimenting with the MCU, it is not helpful and can be obstructive. For this reason, the first line of code on many bench applications is to simply disable the watchdog by setting the WDTHOLD bit.

#### 3.6.5.2 Configuring $V_{CORE}$

Next, main() sets the PMMCOREV register field to 2. PMMCOREV controls the  $V_{CORE}$  voltage, which is the voltage at which the MCU core circuitry operates.  $V_{CORE}$  is generated from a low-dropout (LDO) regulator inside the MCU Power Management Module (PMM). Higher CPU operating speeds require higher  $V_{CORE}$  levels, and higher  $V_{CORE}$  levels result in higher quiescent current on the LDO. For this reason,  $V_{CORE}$  is programmable.

Although primarily related to CPU speed, the device data sheet also shows that during operation of the USB PLL (that is, during an active USB connection),  $V_{\text{CORE}}$  must be set to 2 or 3, the highest two levels. Because the demo's use of an 8-MHz clock does not require a setting of 3, the PMMCOREV register is set to 2.

### 3.6.5.3 Configuring Clocks

MSP430 applications typically use a fast clock and a slow clock. The fast clock (called *MCLK*) sources the CPU and peripherals in some cases, while the slow one keeps timers and peripherals operating during low-power modes. This approach reduces power: slow clocks consume less power, so the more often the fast clock can be disabled, the less power the application may consume.

Typically this fast clock is the digitally controlled oscillator (DCO) integrated in the MCU. The DCO itself is an important low-power tool, because unlike a crystal, it has a very fast start-up time, and thus can be quickly shut down and re-enabled. The DCO can be activated by an interrupt and stabilize fast enough to respond to it. An MCU's low-power modes are only useful if they can be used often.

Many MSP430 devices, including the F5529, couple the DCO with an frequency-locked loop (FLL) module that keeps the DCO locked to a precise slower-frequency reference. This gives good control over the DCO frequency.

The F5529 has three slow clocks available:

- REFO: This is a modestly precise low-power on-chip oscillator that does not require a crystal. It operates at 32 kHz.
- LFXT1: This is a crystal oscillator. It is very precise and lower power than the REFO, but it requires a crystal. It, too, operates at 32 kHz.
- VLO: This oscillator is not very precise but does not require a crystal and has the lowest power of the three. It usually operates somewhere between 12 kHz and 20 kHz.

To keep things simple, the simpleUsbBackchannel example does not use any low-power modes; the CPU stays active at all times. As a result, all of these clocks are constantly active, and all functions are sourced from the DCO FLL. The emulStorageKeyboard example (see [Section 3.5](#)) does make use of low-power modes.

USB operation on the F5529 requires a high-frequency reference clock for the USB PLL. As mentioned in [Section 2.2.5](#), this is sourced on the XT2 oscillator, and the F5529 LaunchPad development kit has a resonator on XT2. XT2 is managed directly by the USB API.

[Table 9](#) shows the simpleUsbBackchannel example's clock configuration.

**Table 9. Clock Settings**

System Clock	Source	Speed	Description
MCLK	DCO, FLL	8 MHz	MCLK is the MSP430 CPU clock. It is disabled in all low-power modes. There is no predefined MCLK lower limit for USB communication, but 8 MHz and higher are commonly used.
SMCLK	DCO, FLL	8 MHz	SMCLK drives high-speed peripherals. It is kept alive during LPM0 but disabled in LPM3, LPM4, and LPM5. LPM0 is the lowest power mode permissible during an active USB connection.
ACLK	REFO	32 kHz	ACLK is a low-speed clock that drives timers and slower peripherals. It is a very low-power way to keep the MCU alive during low-power modes. It is kept alive during LPM3 but disabled in LPM4 and LPM5.
USBCLK	XT2	4 MHz	USB operation on the F5529 requires a $\pm 2500$ -ppm clock source on XT2. This application uses a precise crystal resonator. The USB module receives this clock directly from XT2.

For a full explanation of the MSP430 clock system, see the *Unified Clock System (UCS)* chapter in the [MSP430x5xx and MSP430x6xx Family User's Guide](#).

### 3.6.5.4 Configuring Ports

In the function `initPorts()`, all of the I/Os are configured to drive out-low. Later, in `bcUartInit()`, the `USCI_A1` module's UART pins will be configured for the backchannel UART.

The purpose of `initPorts()` is to eliminate floating inputs. These are a source of unexpected power draw, so it is a good practice to either drive all I/Os out or make sure any inputs are being pulled high or low from the outside. If you drive an I/O out, make sure this does not negatively affect some other component on the board.

### 3.6.5.5 Initializing the Backchannel UART

`bcUartInit()` initializes the backchannel UART. See [Section 3.6.4](#) for more information about configuring the backchannel UART library.

### 3.6.5.6 Configuring USB

`USB_setup()` is called next. This initializes the USB API and enables all of the USB events. It then checks to see if a USB host is already attached, which it determines by the presence of 5 V on the VBUS pin. If attached, it pulls the D+ signal high, telling the host it is there. The host responds by enumerating the device.

Finally, global interrupts are enabled, and execution enters the main loop.

## 3.6.6 Code Description: Main Loop

The following code sample shows the main loop.

```
while(1)
{
    // Receive backchannel UART bytes, send over USB
    rxByteCount = bcUartReceiveBytesInBuffer(buf_bcuartToUsb);
    if(rxByteCount)
    {
        cdcSendDataInBackground(buf_bcuartToUsb, rxByteCount, CDC0_INTFNUM, 1000);
        //hidSendDataInBackground(buf_bcuartToUsb, rxByteCount, HID0_INTFNUM, 1000);
    }
    // Receive USB bytes, send over backchannel UART
    rxByteCount = cdcReceiveDataInBuffer(buf_usbToBcuart,
                                        sizeof(buf_usbToBcuart),
                                        CDC0_INTFNUM);
    /*rxByteCount = hidReceiveDataInBuffer(buf_usbToBcuart,
                                        sizeof(buf_usbToBcuart),
                                        HID0_INTFNUM); */

    if(rxByteCount)
    {
        bcUartSend(buf_usbToBcuart, rxByteCount);
    }
}
```

The main loop does the following actions for both the backchannel UART and USB CDC interface:

- Copies data from their respective input buffers.
- If any data was present, retransmits the data over the other interface.

When data arrives at the `USCI_A1` backchannel UART, it is immediately copied to the receive buffer, `bcUartRcvBuf`. Then, because this main loop never sleeps, it frequently checks if any bytes are waiting in the receive buffer using `bcUartReceiveBytesInBuffer()`. If bytes are waiting, the bytes are copied into `buf_bcuartToUsb`. Then `cdcSendDataInBackground()` sends them over the application's CDC interface to the host PC.

The same happens in the other direction. When data arrives over the USB CDC interface, the USB hardware module places them into the USB endpoint buffers. The main loop calls `cdcReceiveDataInBuffer()`, which checks if any bytes have been received; if so, they are copied into `buf_usbtobcuart`. Then, `bcUartSend()` sends them over the backchannel UART.

When data is sent over a UART, communication generally happens quickly, because it is low-level and has essentially no overhead. After a byte is written to the TXBUF register, the time is very brief before TXBUF is ready to send the next byte. Therefore, `bcUartSend()` does not return until all bytes are sent. Hardware flow control could theoretically keep execution here indefinitely, but it is usually a safe assumption that the eZ-FET lite's MSP430, which is at the other end of this hardware UART connection, will quickly de-assert flow control and be ready to receive data.

Sending data over a USB interface is very different. Multiple communication layers, both hardware and software, exist between the MSP430 application and the bus. There is a higher potential for the host and bus to respond slowly. So, sending data over USB is an interrupt-driven process, involving multiple interrupts over time. Polling in one place until all data is sent is possible but carries some risk of blocking execution.

The USB API provides two construct functions for CDC interfaces. `cdcSendDataWaitTilDone()` waits until the sending is complete before proceeding to the next line of code. `cdcSendDataInBackground()` only initiates the sending operation and returns immediately while data is sent in the background behind subsequent lines of code. However, `cdcSendDataInBackground()` always checks to ensure there is not a previous send operation still open and polls until that operation is complete. Both functions have a *retry* parameter, so they can only block for a limited amount of time.

This example of USB sending and receiving is sufficient for simple situations, but its handling of events like surprise removal of the USB cable is simplistic. If USB is present, it sends data. If not, then it simply returns an error (which is not even checked) and moves forward. More sophisticated applications may need to pay attention to return codes and consider USB surprise removals. The `emulStorageKeyboard` example in [Section 3.5](#) demonstrates this.

### 3.6.7 Modifying to Use an HID-Datapipe Interface

This demo can be easily converted to use an HID-Datapipe interface instead of CDC (see [Figure 34](#)). The advantage of the HID-Datapipe interface is that HID does not require the INF installation process on Windows PCs that CDC does. In exchange for this, it operates with a 64-KB/s bandwidth limit.

HID also does not have the same host-side coding simplicity provided by virtual COM ports. For this reason, TI provides the Java HID Demo App as an example. This demo app and its source code are included in the [MSP430 USB Developers Package](#).

HID-Datapipe is a special version of HID and is part of the MSP430 USB API. It allows communication that is point-to-point, bidirectional, and unformatted, much like a virtual COM port. In contrast, traditional HID relies on highly-formatted *reports*. HID-Datapipe abstracts the application from these reports and presents an interface that is very much like the one used for CDC.

To convert the `simpleUsbBackchannel` example to use HID-Datapipe:

- Use the Descriptor Tool to generate new output in the example's `\USB_config` directory. A Descriptor Tool input file called `simpleUsbBackchannel_HID.dat` is provided in the project directory. Open this file with the Tool, and then generate new output files into `\USB_config`. (For reverting to CDC, another file that is named `simpleUsbBackchannel_CDC.dat` is provided.)
- The code shown in [Section 3.6.6](#) includes alternate calls for HID, which are symmetrical to the ones for CDC. Comment out the CDC calls, and uncomment the ones for HID.

Now, build and run. Download the MSP430 USB Developers Package, and run the Java HID Demo App. The app needs to know the VID and PID reported by the F5529; for the HID version of this example, these are 0x2047 and 0x0404, respectively.

Instructions for using the Java HID Demo App are located in the Examples Guide PDF file in the MSP430 USB Developers Package.

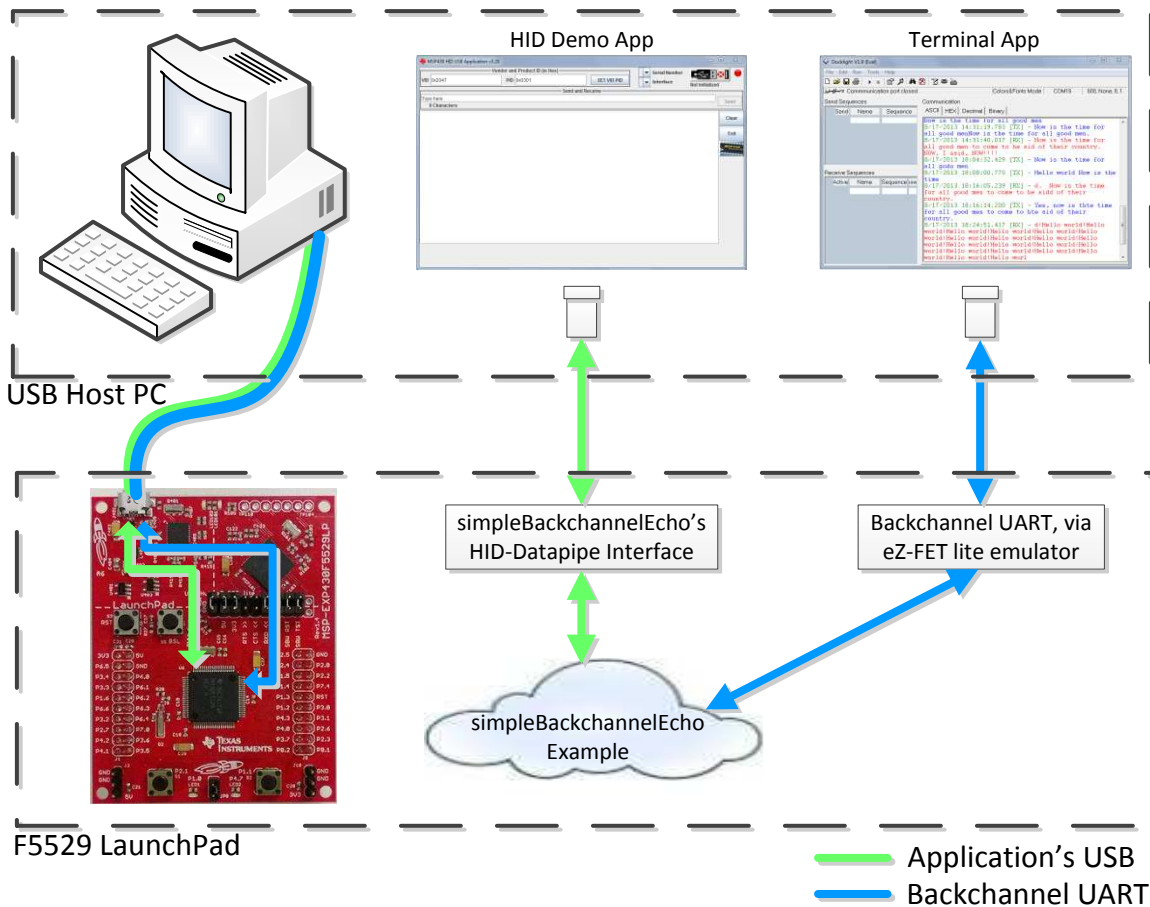

Figure 34. Movement of Data in simpleUsbBackchannel: HID-Datapipe

### 3.7 Starting Device Manager

Device Manager is very useful for determining what USB interfaces have enumerated on the host.

To open Device Manager, click the Start button, click Run..., type "devmgmt.msc" in the Open field, and click OK (see Figure 35).

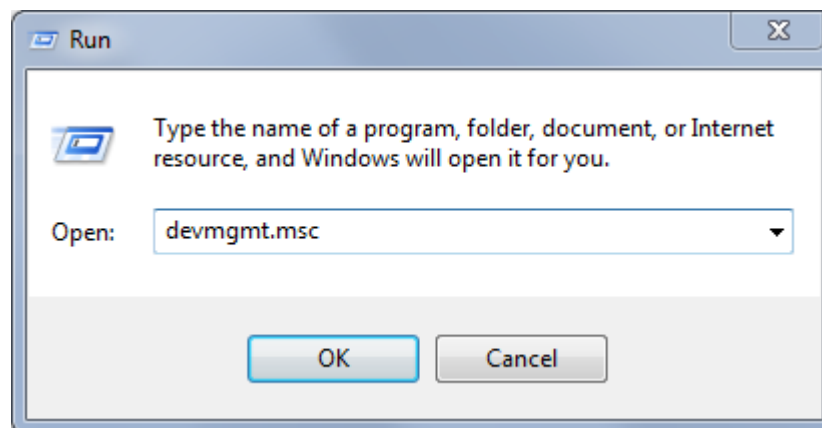
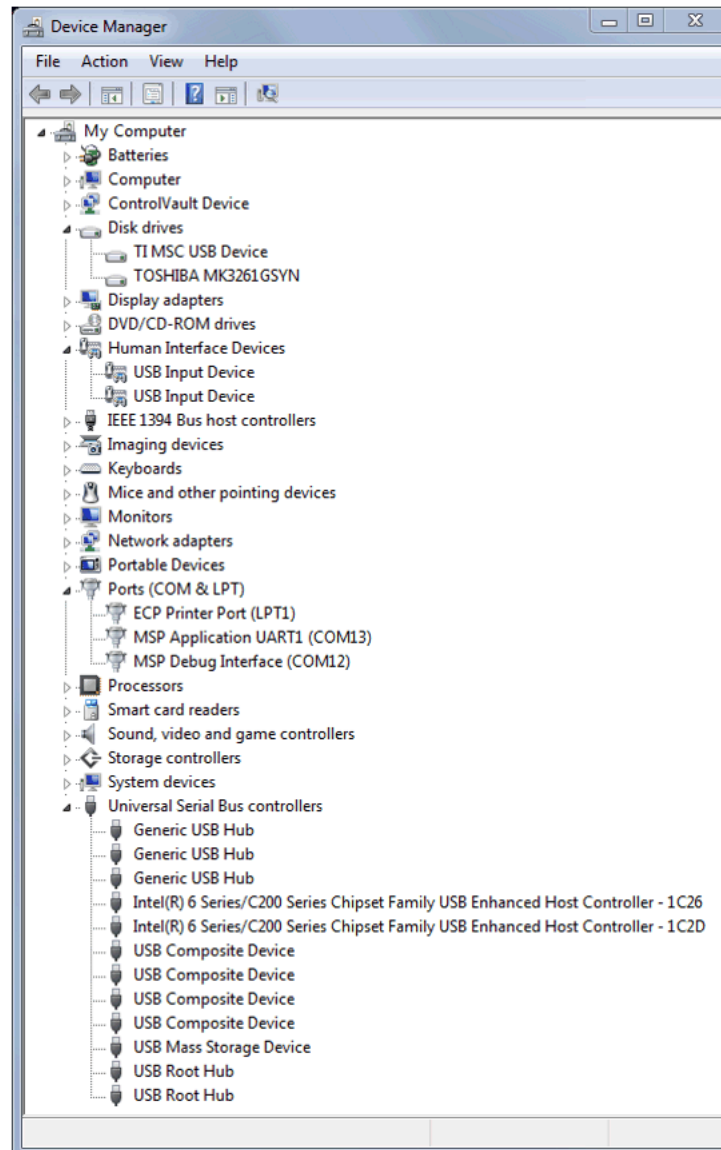

Figure 35. Start Device Manager

If Windows asks if you want to allow the program to make changes to your computer, click Yes; however, Device Manager is very useful for viewing purposes without having to change anything (see [Figure 36](#)).



**Figure 36. Device Manager**

The groups in Device Manager that are relevant to MSP430 USB work include:

- Ports (for virtual COM ports)
- Human Interface Devices (for HID interfaces).
- Disk Drives (for any drives that have been mounted with an MSC interface)
- Universal Serial Bus controllers (Hubs and MSC interfaces appear here, as do root entries for composite USB devices.)

Device Manager is also very useful during debug of a USB application. The *MSP430 USB API Programmer's Guide* in the [MSP430 USB Developers Package](#) contains a section on how to debug your USB application. See this document for more information on using Device Manager.

## 4 Additional Resources

### 4.1 LaunchPad Development Kit Websites

More information about the F5529 LaunchPad development kit, supported BoosterPack plug-in modules, and available resources can be found at:

- [F5529 LaunchPad development kit tool page](#): resources specific to this particular LaunchPad development kit
- [TI's LaunchPad development kit portal](#): information about all LaunchPad development kits from TI for all MCUs



Figure 37. F5529 LaunchPad Development Kit With DLP-7970ABP NFC BoosterPack Plug-in Module

### 4.2 Information on the MSP430F5529

At some point, you will probably want more information about the F5529 device. For every MSP430 device, the documentation is organized as shown in [Table 10](#).

Table 10. How MSP430 Device Documentation is Organized

Document	For MSP430F5529	Description
Device family user's guide	<a href="#">MSP430x5xx and MSP430x6xx Family User's Guide</a>	Architectural information about the device, including clocks, timers, ADC, and so on.
Device-specific data sheet	<a href="#">MSP430F551x, MSP430F552x Mixed Signal Microcontroller</a>	Device-specific information and all parametric information for this device

### 4.3 Download CCS, IAR, mspgcc, or Energia

When you want to write your own programs, you will need one of these [development environments](#).

Currently, the USB API does not support mspgcc. However, you can still use mspgcc to write non-USB software on the F5529 LaunchPad development kit, because the eZ-FET lite supports mspgcc.

As described in [Section 3.2](#), the free version of IAR KickStart has a code-size limit of 8KB, which limits the ability to compile some USB projects.

Energia is an easy-to-use open-source platform. It is a great place to get started if you are new to LaunchPad development kits or are in need of rapid prototyping.

### 4.4 USB Developers Package

The software examples included with the F5529 LaunchPad development kit are built on the materials in the MSP430 USB Developers Package. The developers package includes the USB API, USB Descriptor Tool, 20+ USB examples, the Java HID Demo App, and a detailed programmer's guide to help you get started on writing your own USB applications.



You can obtain the MSP430 USB Developers Package in these ways:

- Download and install [CCS](#), which contains MSP430Ware if the appropriate box is checked during installation.
- Download it as part of [MSP430Ware](#)
- Download it as a [separate download](#)

If you have already installed CCS, you probably already have the USB Developers Package. Click the View menu, click TI Resource Explorer, and go to the USB Developers Package under Libraries.

If using IAR, either MSP430Ware or the USB developers package can be downloaded. The latter is a smaller download but does not include the TI Resource Explorer (see [Section 4.5](#)), the full version of driverlib, and other tools and libraries.

The current revision of the MSP430 USB Developers Package requires CCS v5.5 or IAR v5.51. These are newer versions than are required to run the examples included with the F5529 LaunchPad development kit.

#### **4.5 MSP430Ware and TI Resource Explorer**

[MSP430Ware](#) is a complete collection of libraries and tools. It includes driverlib and the USB Developers Package used in the software demo. By default, MSP430Ware is included in a CCS installation. IAR and mspgcc users must download it separately.

MSP430Ware includes the TI Resource Explorer for easily browsing the tools. For example, [Figure 38](#) shows all of the USB examples in the MSP430 USB Developers Package.

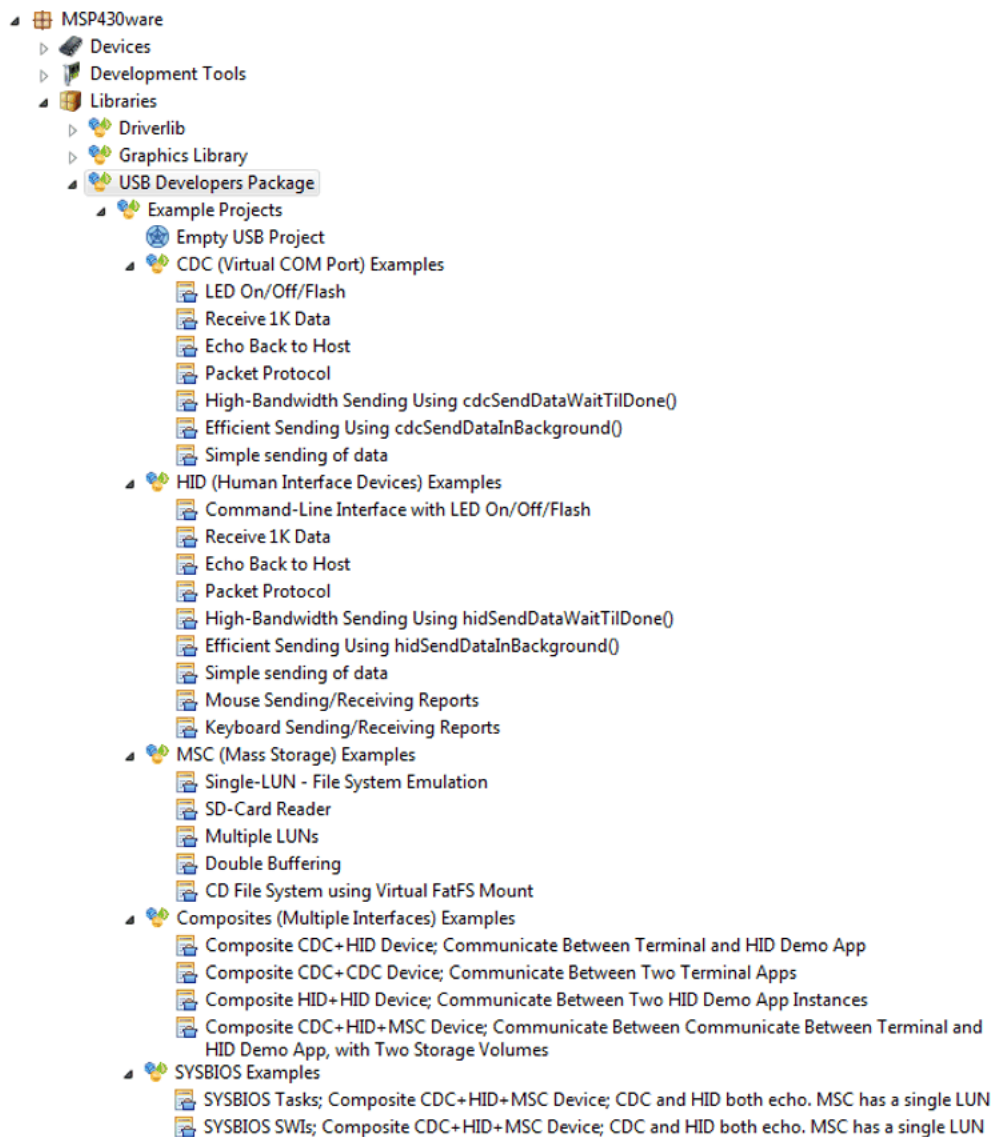

**Figure 38. USB Examples in the USB Developers Package**

The Resource Explorer also has a wizard for creating your own empty USB project (see [Figure 39](#)). It automatically invokes the Descriptor Tool, the tool's help text walks you through all of the decisions you need to make, and finally the tool saves its output files into your new empty USB project!

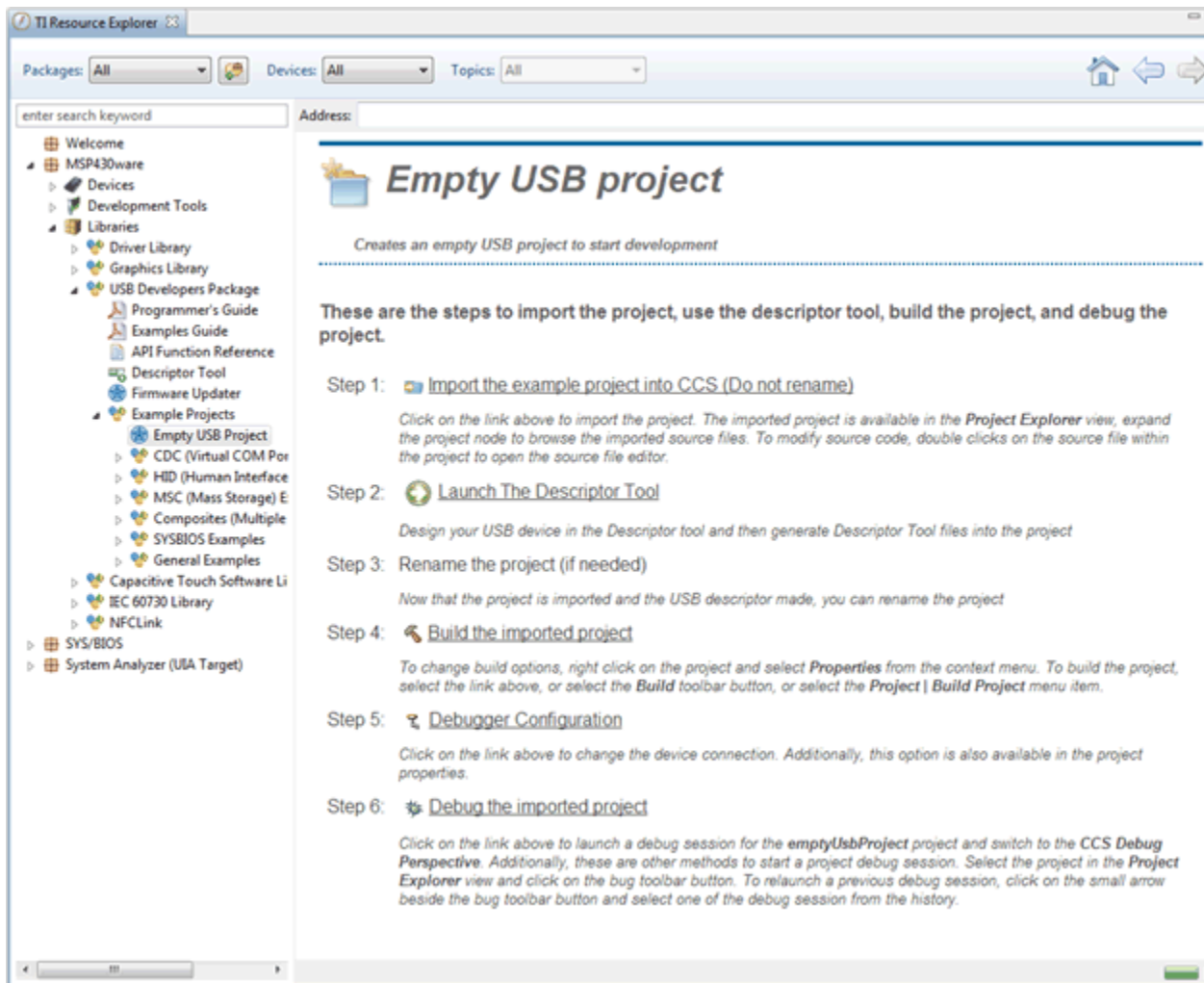

Figure 39. TI Resource Explorer: Create a New USB Project Wizard

Inside TI Resource Explorer, click Libraries, then click USB Developers Package, and finally click Example Projects. Click Empty USB Project.

This feature is only found in MSP430Ware v1.40.01.44 and later, which is distributed in CCS v5.5.

#### 4.6 F5529 Code Examples

This is a set of very simple [code examples](#) that demonstrate how to use the entire set of peripherals on the MSP430 MCU: ADC12, Timer\_A, Timer\_B, and so on. These do not use driverlib; rather, they access the MSP430 registers directly.

Every MSP430 MCU has a set of these code examples. When you write code that uses a peripheral, these examples can often serve as a starting point.

#### 4.7 MSP430 Application Notes

There are many application notes at [www.ti.com/msp430](http://www.ti.com/msp430) with practical design examples and topics.

#### 4.8 TI E2E Community

Search the forums at <http://e2e.ti.com>. If you cannot find your answer, post your question to the community.

## 4.9 Community at Large

Many online communities focus on the MSP430 – for example, <http://www.43oh.com>. You can find additional tools, resources, and support from these communities.

## 5 FAQs

### Q: I can't get the backchannel UART to connect. What's wrong?

A: Check the following:

- Do the baudrate in the host's terminal application and the USCI\_A1 settings match?
- Are the appropriate jumpers in place, on the isolation jumper block?
- Probe on RXD and send data from the host; if you don't see data, it might be a problem on the host side.
- Probe on TXD while sending data from the MSP430. If you don't see data, it might be a configuration problem on the USCI\_A1 module.
- Consider the use of the hardware flow control lines (especially for higher baud rates)

### Q: So the onboard emulator is really open source? And I can build my own onboard emulator?

A: Yes! We encourage you to do so. The design files are on ti.com.

### Q: Why are the character strings printed to the screen incorrect when using the keyboard demo?

A: If you are using a different regional keyboard, certain characters may appear differently. This can be fixed by opening the \*.txt files and entering new strings.

### Q: My ASCII art rocket does not look right?

A: A couple possibilities...

- If typing the rocket into Notepad++, the image can become skewed due to a setting that automatically tabs into the next line after a carriage return. You can fix this by changing these settings or by using the standard Notepad application or another text editor. (To open Notepad, click the Start button, then click Run..., type "notepad" in the Open text box, and click OK.)
- If you are using a word processor like Microsoft Word, be sure to use a fixed-width font like Courier New.

### Q: I tried building my own project with driverlib and got a warning: "#303-D typedef name has already been declared (with same type)." How do I resolve this?

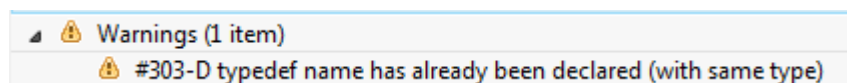

A: This warning can occur with CCS v5.4. The version of driverlib in the F5529 LaunchPad development kit software examples is from MSP430Ware v1.40.01.44, which is targeted at CCS v5.5. CCS v5.5 has a new and improved set of MSP430 header files in it (for example, msp430f5529.h), and the driverlib in these examples is dependent on that new header file. To resolve this problem in the demo, TI put the new and improved header file (from CCS v5.5) into this project, allowing the project to be compatible with v5.4. However, if you are now working with a different project, this new header file may be missing. You can copy the msp430f5529.h file out of the demo project into your project, or you can upgrade to CCS v5.5.

### Q: The MSP430 G2 LaunchPad development kit had a socket, allowing me change the target device. Why doesn't the F5529 LaunchPad development kit use one?

A: The F5529 LaunchPad development kit provides more functionality, and this requires it to use a device with more pins. Sockets for devices with this many pins are too expensive for the tool's target price.

**Q: I'm trying to power the LaunchPad development kit from a USB power supply (not an actual USB host), and it is not working. Does the LaunchPad development kit not support this?**

This problem is fixed in Rev1.5 and later LaunchPad development kits. Unfortunately Rev1.4 does not. USB hubs typically shouldn't enable power to their downstream devices until the hubs themselves enumerate on the host, and that's what the TUSB2046 on the Rev1.4 F5529 LaunchPad development kit does through the TPS2041B power switches. If the hub never enumerates, power is not provided to the target F5529. Because the downstream device is permanently attached in this application, the TPS2041B switches are not required by the USB specification. Rev1.5 and newer F5529 LaunchPad development kits have these switches removed, to avoid this problem.

Again, the benefit of the hub is single-cable development. Other power supplies can still be applied through the power header.

**Q: With the female headers on the bottom, the board does not sit flat on the table, and I can't unsolder them. Why did TI do this?**

A: For several reasons. A major feedback item on previous LaunchPad development kits was the desire for female headers instead of male ones. But simply using female instead is problematic, because compatibility with existing BoosterPack plug-in modules would be lost, and some people prefer male headers. So, adding female headers without removing male ones satisfies both preferences. It also allows more flexibility in stacking BoosterPack plug-in modules and other LaunchPad development kits.

The downside to this approach is perhaps that the board does not sit flat. But while a USB cable is attached (the usual development model), it tends to not sit flat anyway.

For those wishing the board to sit flat, holes are drilled in the corners so that standoffs can be fastened. Rubber bumper feet also should work.

6 Schematics

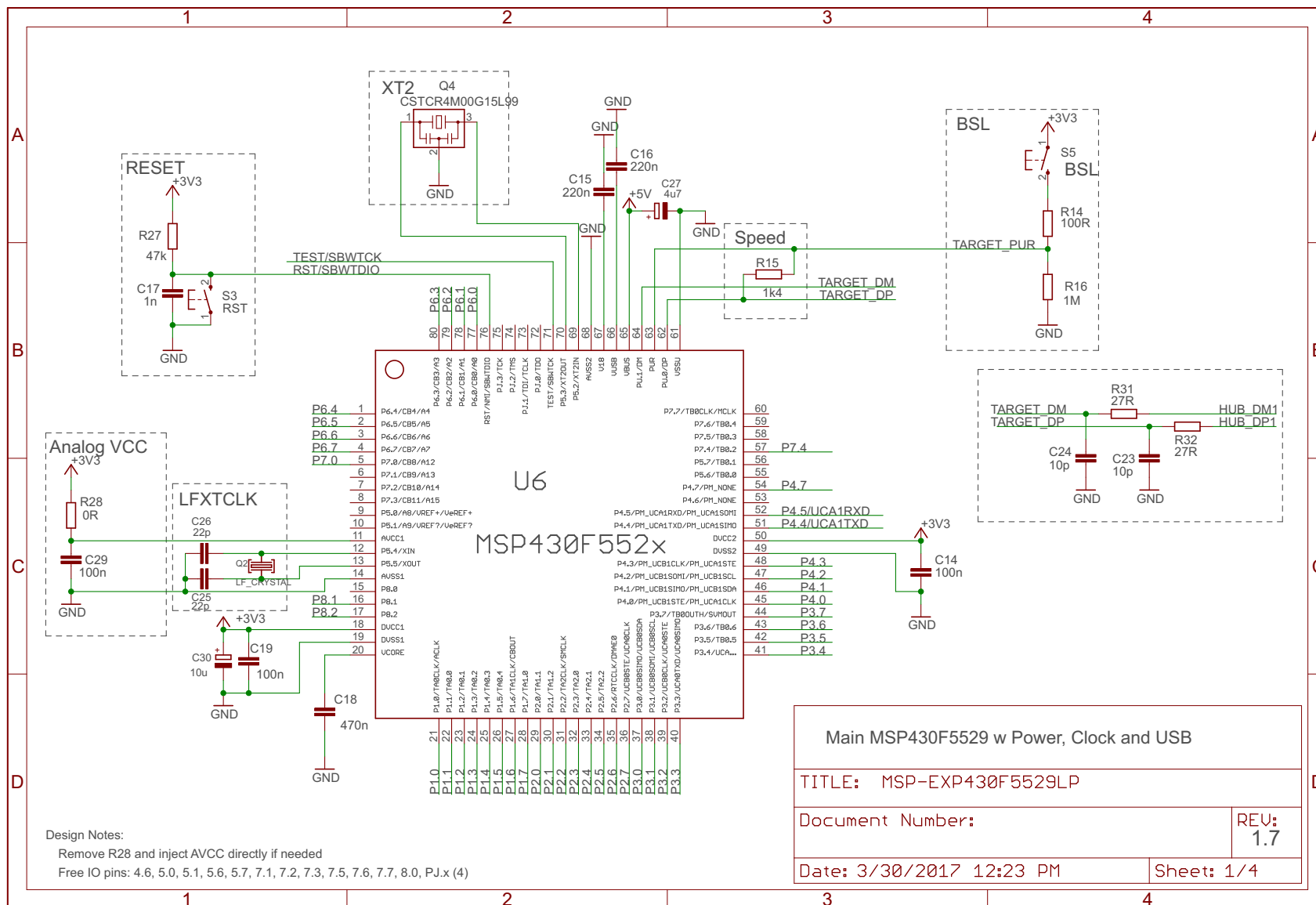

Copyright © 2017, Texas Instruments Incorporated

Figure 40. Schematics (1 of 4)

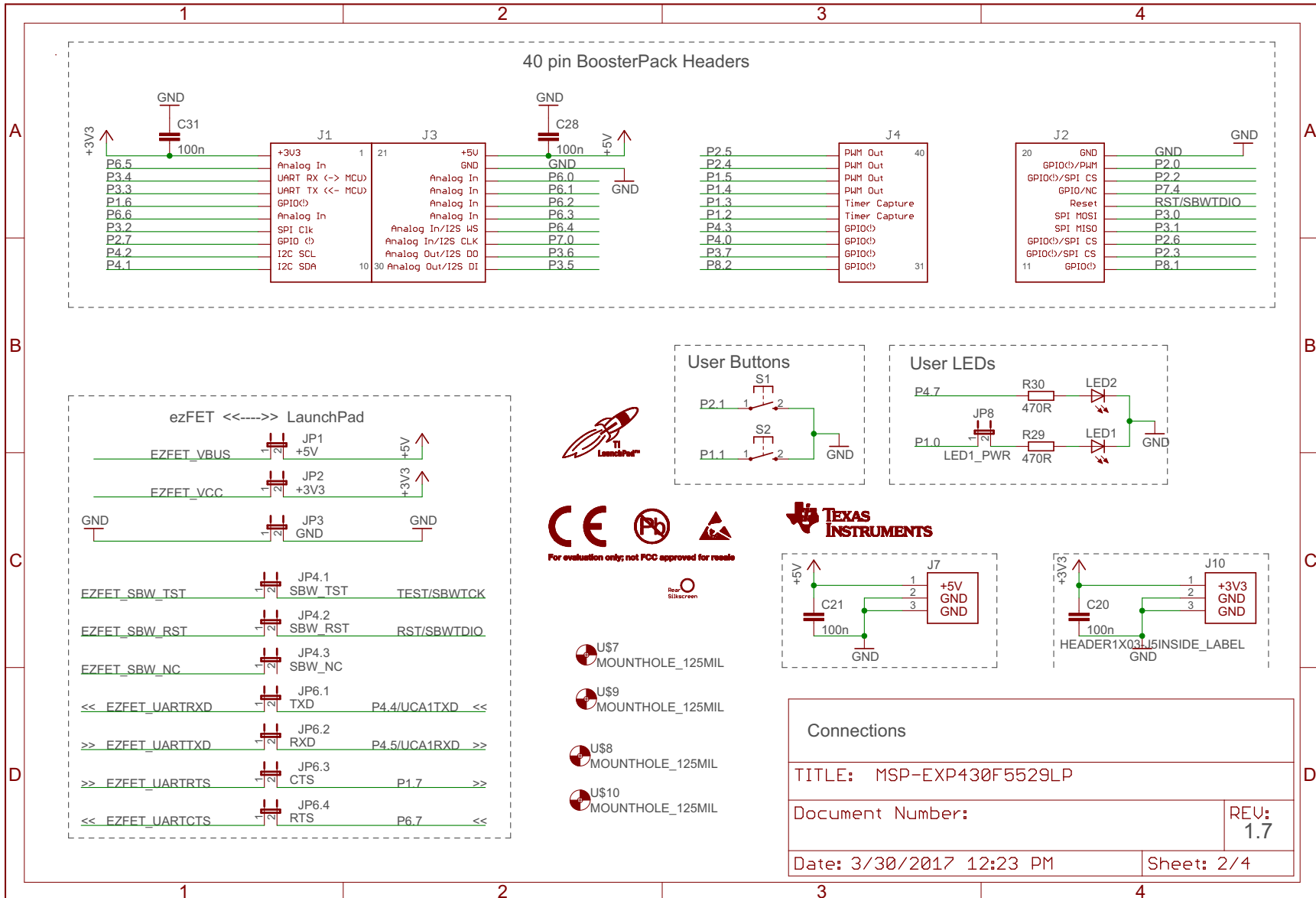
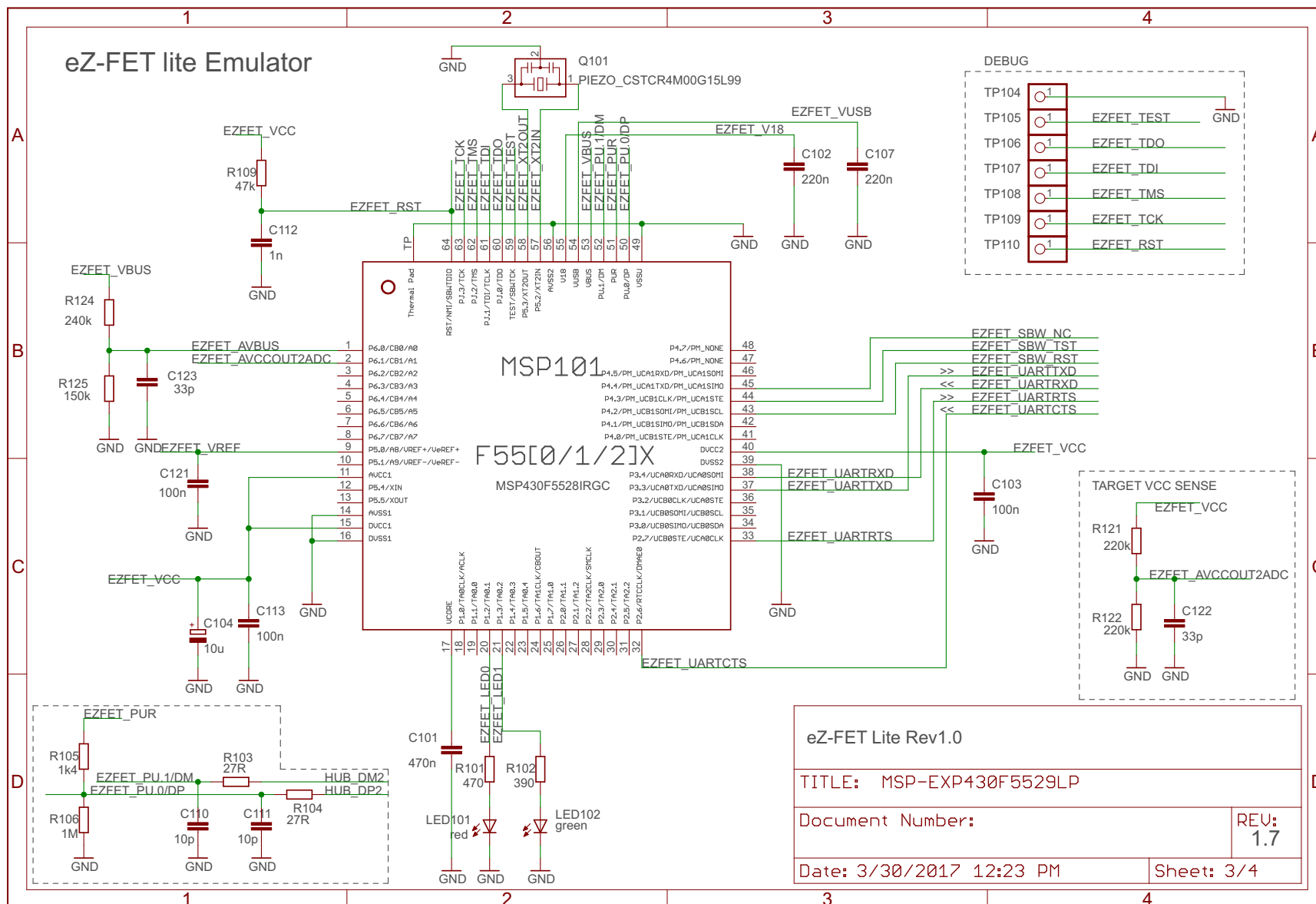

Figure 41. Schematics (2 of 4)



Copyright © 2017, Texas Instruments Incorporated

Figure 42. Schematics (3 of 4)



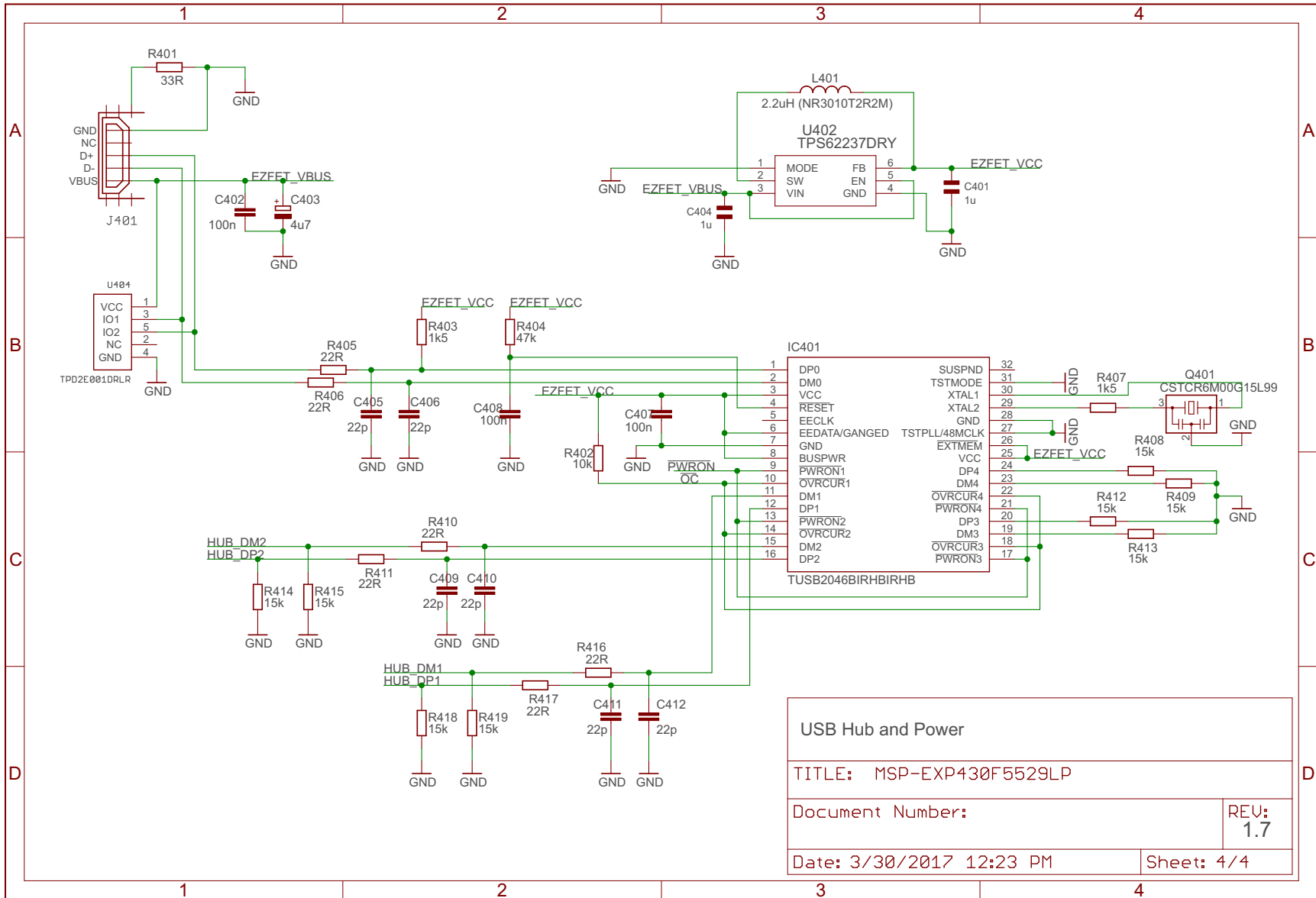

Copyright © 2017, Texas Instruments Incorporated

Figure 43. Schematics (4 of 4)

## Revision History

NOTE: Page numbers for previous revisions may differ from page numbers in the current version.

<b>Changes from July 22, 2015 to April 7, 2017</b>		<b>Page</b>
• Added Rev 1.6 and Rev 1.7 to <a href="#">Table 4</a> , <i>Hardware Change Log</i> .....		27
• Updated all of the figures in <a href="#">Section 6</a> , <i>Schematics</i> .....		54

## STANDARD TERMS FOR EVALUATION MODULES

1. *Delivery:* TI delivers TI evaluation boards, kits, or modules, including any accompanying demonstration software, components, and/or documentation which may be provided together or separately (collectively, an "EVM" or "EVMs") to the User ("User") in accordance with the terms set forth herein. User's acceptance of the EVM is expressly subject to the following terms.
  - 1.1 EVMs are intended solely for product or software developers for use in a research and development setting to facilitate feasibility evaluation, experimentation, or scientific analysis of TI semiconductor products. EVMs have no direct function and are not finished products. EVMs shall not be directly or indirectly assembled as a part or subassembly in any finished product. For clarification, any software or software tools provided with the EVM ("Software") shall not be subject to the terms and conditions set forth herein but rather shall be subject to the applicable terms that accompany such Software
  - 1.2 EVMs are not intended for consumer or household use. EVMs may not be sold, sublicensed, leased, rented, loaned, assigned, or otherwise distributed for commercial purposes by Users, in whole or in part, or used in any finished product or production system.
2. *Limited Warranty and Related Remedies/Disclaimers:*
  - 2.1 These terms do not apply to Software. The warranty, if any, for Software is covered in the applicable Software License Agreement.
  - 2.2 TI warrants that the TI EVM will conform to TI's published specifications for ninety (90) days after the date TI delivers such EVM to User. Notwithstanding the foregoing, TI shall not be liable for a nonconforming EVM if (a) the nonconformity was caused by neglect, misuse or mistreatment by an entity other than TI, including improper installation or testing, or for any EVMs that have been altered or modified in any way by an entity other than TI, (b) the nonconformity resulted from User's design, specifications or instructions for such EVMs or improper system design, or (c) User has not paid on time. Testing and other quality control techniques are used to the extent TI deems necessary. TI does not test all parameters of each EVM. User's claims against TI under this Section 2 are void if User fails to notify TI of any apparent defects in the EVMs within ten (10) business days after delivery, or of any hidden defects with ten (10) business days after the defect has been detected.
  - 2.3 TI's sole liability shall be at its option to repair or replace EVMs that fail to conform to the warranty set forth above, or credit User's account for such EVM. TI's liability under this warranty shall be limited to EVMs that are returned during the warranty period to the address designated by TI and that are determined by TI not to conform to such warranty. If TI elects to repair or replace such EVM, TI shall have a reasonable time to repair such EVM or provide replacements. Repaired EVMs shall be warranted for the remainder of the original warranty period. Replaced EVMs shall be warranted for a new full ninety (90) day warranty period.
3. *Regulatory Notices:*
  - 3.1 *United States*
    - 3.1.1 *Notice applicable to EVMs not FCC-Approved:*

**FCC NOTICE:** This kit is designed to allow product developers to evaluate electronic components, circuitry, or software associated with the kit to determine whether to incorporate such items in a finished product and software developers to write software applications for use with the end product. This kit is not a finished product and when assembled may not be resold or otherwise marketed unless all required FCC equipment authorizations are first obtained. Operation is subject to the condition that this product not cause harmful interference to licensed radio stations and that this product accept harmful interference. Unless the assembled kit is designed to operate under part 15, part 18 or part 95 of this chapter, the operator of the kit must operate under the authority of an FCC license holder or must secure an experimental authorization under part 5 of this chapter.
    - 3.1.2 *For EVMs annotated as FCC – FEDERAL COMMUNICATIONS COMMISSION Part 15 Compliant:*

### CAUTION

This device complies with part 15 of the FCC Rules. Operation is subject to the following two conditions: (1) This device may not cause harmful interference, and (2) this device must accept any interference received, including interference that may cause undesired operation.

Changes or modifications not expressly approved by the party responsible for compliance could void the user's authority to operate the equipment.

### FCC Interference Statement for Class A EVM devices

*NOTE: This equipment has been tested and found to comply with the limits for a Class A digital device, pursuant to part 15 of the FCC Rules. These limits are designed to provide reasonable protection against harmful interference when the equipment is operated in a commercial environment. This equipment generates, uses, and can radiate radio frequency energy and, if not installed and used in accordance with the instruction manual, may cause harmful interference to radio communications. Operation of this equipment in a residential area is likely to cause harmful interference in which case the user will be required to correct the interference at his own expense.*

## FCC Interference Statement for Class B EVM devices

*NOTE: This equipment has been tested and found to comply with the limits for a Class B digital device, pursuant to part 15 of the FCC Rules. These limits are designed to provide reasonable protection against harmful interference in a residential installation. This equipment generates, uses and can radiate radio frequency energy and, if not installed and used in accordance with the instructions, may cause harmful interference to radio communications. However, there is no guarantee that interference will not occur in a particular installation. If this equipment does cause harmful interference to radio or television reception, which can be determined by turning the equipment off and on, the user is encouraged to try to correct the interference by one or more of the following measures:*

- Reorient or relocate the receiving antenna.
- Increase the separation between the equipment and receiver.
- Connect the equipment into an outlet on a circuit different from that to which the receiver is connected.
- Consult the dealer or an experienced radio/TV technician for help.

### 3.2 Canada

3.2.1 For EVMs issued with an Industry Canada Certificate of Conformance to RSS-210 or RSS-247

#### Concerning EVMs Including Radio Transmitters:

This device complies with Industry Canada license-exempt RSSs. Operation is subject to the following two conditions:

(1) this device may not cause interference, and (2) this device must accept any interference, including interference that may cause undesired operation of the device.

#### Concernant les EVMs avec appareils radio:

Le présent appareil est conforme aux CNR d'Industrie Canada applicables aux appareils radio exempts de licence. L'exploitation est autorisée aux deux conditions suivantes: (1) l'appareil ne doit pas produire de brouillage, et (2) l'utilisateur de l'appareil doit accepter tout brouillage radioélectrique subi, même si le brouillage est susceptible d'en compromettre le fonctionnement.

#### Concerning EVMs Including Detachable Antennas:

Under Industry Canada regulations, this radio transmitter may only operate using an antenna of a type and maximum (or lesser) gain approved for the transmitter by Industry Canada. To reduce potential radio interference to other users, the antenna type and its gain should be so chosen that the equivalent isotropically radiated power (e.i.r.p.) is not more than that necessary for successful communication. This radio transmitter has been approved by Industry Canada to operate with the antenna types listed in the user guide with the maximum permissible gain and required antenna impedance for each antenna type indicated. Antenna types not included in this list, having a gain greater than the maximum gain indicated for that type, are strictly prohibited for use with this device.

#### Concernant les EVMs avec antennes détachables

Conformément à la réglementation d'Industrie Canada, le présent émetteur radio peut fonctionner avec une antenne d'un type et d'un gain maximal (ou inférieur) approuvé pour l'émetteur par Industrie Canada. Dans le but de réduire les risques de brouillage radioélectrique à l'intention des autres utilisateurs, il faut choisir le type d'antenne et son gain de sorte que la puissance isotrope rayonnée équivalente (p.i.r.e.) ne dépasse pas l'intensité nécessaire à l'établissement d'une communication satisfaisante. Le présent émetteur radio a été approuvé par Industrie Canada pour fonctionner avec les types d'antenne énumérés dans le manuel d'usage et ayant un gain admissible maximal et l'impédance requise pour chaque type d'antenne. Les types d'antenne non inclus dans cette liste, ou dont le gain est supérieur au gain maximal indiqué, sont strictement interdits pour l'exploitation de l'émetteur.

### 3.3 Japan

3.3.1 *Notice for EVMs delivered in Japan:* Please see [http://www.tij.co.jp/lstds/ti\\_ja/general/eStore/notice\\_01.page](http://www.tij.co.jp/lstds/ti_ja/general/eStore/notice_01.page) 日本国内に輸入される評価用キット、ボードについては、次のところをご覧ください。  
[http://www.tij.co.jp/lstds/ti\\_ja/general/eStore/notice\\_01.page](http://www.tij.co.jp/lstds/ti_ja/general/eStore/notice_01.page)

3.3.2 *Notice for Users of EVMs Considered "Radio Frequency Products" in Japan:* EVMs entering Japan may not be certified by TI as conforming to Technical Regulations of Radio Law of Japan.

If User uses EVMs in Japan, not certified to Technical Regulations of Radio Law of Japan, User is required to follow the instructions set forth by Radio Law of Japan, which includes, but is not limited to, the instructions below with respect to EVMs (which for the avoidance of doubt are stated strictly for convenience and should be verified by User):

1. Use EVMs in a shielded room or any other test facility as defined in the notification #173 issued by Ministry of Internal Affairs and Communications on March 28, 2006, based on Sub-section 1.1 of Article 6 of the Ministry's Rule for Enforcement of Radio Law of Japan,
2. Use EVMs only after User obtains the license of Test Radio Station as provided in Radio Law of Japan with respect to EVMs, or
3. Use of EVMs only after User obtains the Technical Regulations Conformity Certification as provided in Radio Law of Japan with respect to EVMs. Also, do not transfer EVMs, unless User gives the same notice above to the transferee. Please note that if User does not follow the instructions above, User will be subject to penalties of Radio Law of Japan.

【無線電波を送信する製品の開発キットをお使いになる際の注意事項】 開発キットの中には技術基準適合証明を受けていないものがあります。技術適合証明を受けていないものご使用に際しては、電波法遵守のため、以下のいずれかの措置を取っていただく必要がありますのでご注意ください。

1. 電波法施行規則第6条第1項第1号に基づく平成18年3月28日総務省告示第173号で定められた電波暗室等の試験設備でご使用いただく。
2. 実験局の免許を取得後ご使用いただく。
3. 技術基準適合証明を取得後ご使用いただく。

なお、本製品は、上記の「ご使用にあたっての注意」を譲渡先、移転先に通知しない限り、譲渡、移転できないものとします。

上記を遵守頂けない場合は、電波法の罰則が適用される可能性があることをご留意ください。日本テキサス・インスツルメンツ株式会社  
東京都新宿区西新宿 6 丁目 2 4 番 1 号  
西新宿三井ビル

3.3.3 *Notice for EVMs for Power Line Communication:* Please see [http://www.tij.co.jp/lstds/ti\\_ja/general/eStore/notice\\_02.page](http://www.tij.co.jp/lstds/ti_ja/general/eStore/notice_02.page)  
電力線搬送波通信についての開発キットをお使いになる際の注意事項については、次のところをご覧ください。 [http://www.tij.co.jp/lstds/ti\\_ja/general/eStore/notice\\_02.page](http://www.tij.co.jp/lstds/ti_ja/general/eStore/notice_02.page)

#### 3.4 *European Union*

##### 3.4.1 *For EVMs subject to EU Directive 2014/30/EU (Electromagnetic Compatibility Directive):*

This is a class A product intended for use in environments other than domestic environments that are connected to a low-voltage power-supply network that supplies buildings used for domestic purposes. In a domestic environment this product may cause radio interference in which case the user may be required to take adequate measures.

#### 4 *EVM Use Restrictions and Warnings:*

4.1 EVMS ARE NOT FOR USE IN FUNCTIONAL SAFETY AND/OR SAFETY CRITICAL EVALUATIONS, INCLUDING BUT NOT LIMITED TO EVALUATIONS OF LIFE SUPPORT APPLICATIONS.

4.2 User must read and apply the user guide and other available documentation provided by TI regarding the EVM prior to handling or using the EVM, including without limitation any warning or restriction notices. The notices contain important safety information related to, for example, temperatures and voltages.

##### 4.3 *Safety-Related Warnings and Restrictions:*

4.3.1 User shall operate the EVM within TI's recommended specifications and environmental considerations stated in the user guide, other available documentation provided by TI, and any other applicable requirements and employ reasonable and customary safeguards. Exceeding the specified performance ratings and specifications (including but not limited to input and output voltage, current, power, and environmental ranges) for the EVM may cause personal injury or death, or property damage. If there are questions concerning performance ratings and specifications, User should contact a TI field representative prior to connecting interface electronics including input power and intended loads. Any loads applied outside of the specified output range may also result in unintended and/or inaccurate operation and/or possible permanent damage to the EVM and/or interface electronics. Please consult the EVM user guide prior to connecting any load to the EVM output. If there is uncertainty as to the load specification, please contact a TI field representative. During normal operation, even with the inputs and outputs kept within the specified allowable ranges, some circuit components may have elevated case temperatures. These components include but are not limited to linear regulators, switching transistors, pass transistors, current sense resistors, and heat sinks, which can be identified using the information in the associated documentation. When working with the EVM, please be aware that the EVM may become very warm.

4.3.2 EVMs are intended solely for use by technically qualified, professional electronics experts who are familiar with the dangers and application risks associated with handling electrical mechanical components, systems, and subsystems. User assumes all responsibility and liability for proper and safe handling and use of the EVM by User or its employees, affiliates, contractors or designees. User assumes all responsibility and liability to ensure that any interfaces (electronic and/or mechanical) between the EVM and any human body are designed with suitable isolation and means to safely limit accessible leakage currents to minimize the risk of electrical shock hazard. User assumes all responsibility and liability for any improper or unsafe handling or use of the EVM by User or its employees, affiliates, contractors or designees.

4.4 User assumes all responsibility and liability to determine whether the EVM is subject to any applicable international, federal, state, or local laws and regulations related to User's handling and use of the EVM and, if applicable, User assumes all responsibility and liability for compliance in all respects with such laws and regulations. User assumes all responsibility and liability for proper disposal and recycling of the EVM consistent with all applicable international, federal, state, and local requirements.

5. *Accuracy of Information:* To the extent TI provides information on the availability and function of EVMs, TI attempts to be as accurate as possible. However, TI does not warrant the accuracy of EVM descriptions, EVM availability or other information on its websites as accurate, complete, reliable, current, or error-free.

6. *Disclaimers:*

6.1 EXCEPT AS SET FORTH ABOVE, EVMS AND ANY MATERIALS PROVIDED WITH THE EVM (INCLUDING, BUT NOT LIMITED TO, REFERENCE DESIGNS AND THE DESIGN OF THE EVM ITSELF) ARE PROVIDED "AS IS" AND "WITH ALL FAULTS." TI DISCLAIMS ALL OTHER WARRANTIES, EXPRESS OR IMPLIED, REGARDING SUCH ITEMS, INCLUDING BUT NOT LIMITED TO ANY EPIDEMIC FAILURE WARRANTY OR IMPLIED WARRANTIES OF MERCHANTABILITY OR FITNESS FOR A PARTICULAR PURPOSE OR NON-INFRINGEMENT OF ANY THIRD PARTY PATENTS, COPYRIGHTS, TRADE SECRETS OR OTHER INTELLECTUAL PROPERTY RIGHTS.

6.2 EXCEPT FOR THE LIMITED RIGHT TO USE THE EVM SET FORTH HEREIN, NOTHING IN THESE TERMS SHALL BE CONSTRUED AS GRANTING OR CONFERRING ANY RIGHTS BY LICENSE, PATENT, OR ANY OTHER INDUSTRIAL OR INTELLECTUAL PROPERTY RIGHT OF TI, ITS SUPPLIERS/LICENSORS OR ANY OTHER THIRD PARTY, TO USE THE EVM IN ANY FINISHED END-USER OR READY-TO-USE FINAL PRODUCT, OR FOR ANY INVENTION, DISCOVERY OR IMPROVEMENT, REGARDLESS OF WHEN MADE, CONCEIVED OR ACQUIRED.

7. *USER'S INDEMNITY OBLIGATIONS AND REPRESENTATIONS.* USER WILL DEFEND, INDEMNIFY AND HOLD TI, ITS LICENSORS AND THEIR REPRESENTATIVES HARMLESS FROM AND AGAINST ANY AND ALL CLAIMS, DAMAGES, LOSSES, EXPENSES, COSTS AND LIABILITIES (COLLECTIVELY, "CLAIMS") ARISING OUT OF OR IN CONNECTION WITH ANY HANDLING OR USE OF THE EVM THAT IS NOT IN ACCORDANCE WITH THESE TERMS. THIS OBLIGATION SHALL APPLY WHETHER CLAIMS ARISE UNDER STATUTE, REGULATION, OR THE LAW OF TORT, CONTRACT OR ANY OTHER LEGAL THEORY, AND EVEN IF THE EVM FAILS TO PERFORM AS DESCRIBED OR EXPECTED.

8. *Limitations on Damages and Liability:*

8.1 *General Limitations.* IN NO EVENT SHALL TI BE LIABLE FOR ANY SPECIAL, COLLATERAL, INDIRECT, PUNITIVE, INCIDENTAL, CONSEQUENTIAL, OR EXEMPLARY DAMAGES IN CONNECTION WITH OR ARISING OUT OF THESE TERMS OR THE USE OF THE EVMS, REGARDLESS OF WHETHER TI HAS BEEN ADVISED OF THE POSSIBILITY OF SUCH DAMAGES. EXCLUDED DAMAGES INCLUDE, BUT ARE NOT LIMITED TO, COST OF REMOVAL OR REINSTALLATION, ANCILLARY COSTS TO THE PROCUREMENT OF SUBSTITUTE GOODS OR SERVICES, RETESTING, OUTSIDE COMPUTER TIME, LABOR COSTS, LOSS OF GOODWILL, LOSS OF PROFITS, LOSS OF SAVINGS, LOSS OF USE, LOSS OF DATA, OR BUSINESS INTERRUPTION. NO CLAIM, SUIT OR ACTION SHALL BE BROUGHT AGAINST TI MORE THAN TWELVE (12) MONTHS AFTER THE EVENT THAT GAVE RISE TO THE CAUSE OF ACTION HAS OCCURRED.

8.2 *Specific Limitations.* IN NO EVENT SHALL TI'S AGGREGATE LIABILITY FROM ANY USE OF AN EVM PROVIDED HEREUNDER, INCLUDING FROM ANY WARRANTY, INDEMNITY OR OTHER OBLIGATION ARISING OUT OF OR IN CONNECTION WITH THESE TERMS, EXCEED THE TOTAL AMOUNT PAID TO TI BY USER FOR THE PARTICULAR EVM(S) AT ISSUE DURING THE PRIOR TWELVE (12) MONTHS WITH RESPECT TO WHICH LOSSES OR DAMAGES ARE CLAIMED. THE EXISTENCE OF MORE THAN ONE CLAIM SHALL NOT ENLARGE OR EXTEND THIS LIMIT.

9. *Return Policy.* Except as otherwise provided, TI does not offer any refunds, returns, or exchanges. Furthermore, no return of EVM(s) will be accepted if the package has been opened and no return of the EVM(s) will be accepted if they are damaged or otherwise not in a resalable condition. If User feels it has been incorrectly charged for the EVM(s) it ordered or that delivery violates the applicable order, User should contact TI. All refunds will be made in full within thirty (30) working days from the return of the components(s), excluding any postage or packaging costs.

10. *Governing Law:* These terms and conditions shall be governed by and interpreted in accordance with the laws of the State of Texas, without reference to conflict-of-laws principles. User agrees that non-exclusive jurisdiction for any dispute arising out of or relating to these terms and conditions lies within courts located in the State of Texas and consents to venue in Dallas County, Texas. Notwithstanding the foregoing, any judgment may be enforced in any United States or foreign court, and TI may seek injunctive relief in any United States or foreign court.

## IMPORTANT NOTICE FOR TI DESIGN INFORMATION AND RESOURCES

Texas Instruments Incorporated ("TI") technical, application or other design advice, services or information, including, but not limited to, reference designs and materials relating to evaluation modules, (collectively, "TI Resources") are intended to assist designers who are developing applications that incorporate TI products; by downloading, accessing or using any particular TI Resource in any way, you (individually or, if you are acting on behalf of a company, your company) agree to use it solely for this purpose and subject to the terms of this Notice.

TI's provision of TI Resources does not expand or otherwise alter TI's applicable published warranties or warranty disclaimers for TI products, and no additional obligations or liabilities arise from TI providing such TI Resources. TI reserves the right to make corrections, enhancements, improvements and other changes to its TI Resources.

You understand and agree that you remain responsible for using your independent analysis, evaluation and judgment in designing your applications and that you have full and exclusive responsibility to assure the safety of your applications and compliance of your applications (and of all TI products used in or for your applications) with all applicable regulations, laws and other applicable requirements. You represent that, with respect to your applications, you have all the necessary expertise to create and implement safeguards that (1) anticipate dangerous consequences of failures, (2) monitor failures and their consequences, and (3) lessen the likelihood of failures that might cause harm and take appropriate actions. You agree that prior to using or distributing any applications that include TI products, you will thoroughly test such applications and the functionality of such TI products as used in such applications. TI has not conducted any testing other than that specifically described in the published documentation for a particular TI Resource.

You are authorized to use, copy and modify any individual TI Resource only in connection with the development of applications that include the TI product(s) identified in such TI Resource. NO OTHER LICENSE, EXPRESS OR IMPLIED, BY ESTOPPEL OR OTHERWISE TO ANY OTHER TI INTELLECTUAL PROPERTY RIGHT, AND NO LICENSE TO ANY TECHNOLOGY OR INTELLECTUAL PROPERTY RIGHT OF TI OR ANY THIRD PARTY IS GRANTED HEREIN, including but not limited to any patent right, copyright, mask work right, or other intellectual property right relating to any combination, machine, or process in which TI products or services are used. Information regarding or referencing third-party products or services does not constitute a license to use such products or services, or a warranty or endorsement thereof. Use of TI Resources may require a license from a third party under the patents or other intellectual property of the third party, or a license from TI under the patents or other intellectual property of TI.

TI RESOURCES ARE PROVIDED "AS IS" AND WITH ALL FAULTS. TI DISCLAIMS ALL OTHER WARRANTIES OR REPRESENTATIONS, EXPRESS OR IMPLIED, REGARDING TI RESOURCES OR USE THEREOF, INCLUDING BUT NOT LIMITED TO ACCURACY OR COMPLETENESS, TITLE, ANY EPIDEMIC FAILURE WARRANTY AND ANY IMPLIED WARRANTIES OF MERCHANTABILITY, FITNESS FOR A PARTICULAR PURPOSE, AND NON-INFRINGEMENT OF ANY THIRD PARTY INTELLECTUAL PROPERTY RIGHTS.

TI SHALL NOT BE LIABLE FOR AND SHALL NOT DEFEND OR INDEMNIFY YOU AGAINST ANY CLAIM, INCLUDING BUT NOT LIMITED TO ANY INFRINGEMENT CLAIM THAT RELATES TO OR IS BASED ON ANY COMBINATION OF PRODUCTS EVEN IF DESCRIBED IN TI RESOURCES OR OTHERWISE. IN NO EVENT SHALL TI BE LIABLE FOR ANY ACTUAL, DIRECT, SPECIAL, COLLATERAL, INDIRECT, PUNITIVE, INCIDENTAL, CONSEQUENTIAL OR EXEMPLARY DAMAGES IN CONNECTION WITH OR ARISING OUT OF TI RESOURCES OR USE THEREOF, AND REGARDLESS OF WHETHER TI HAS BEEN ADVISED OF THE POSSIBILITY OF SUCH DAMAGES.

You agree to fully indemnify TI and its representatives against any damages, costs, losses, and/or liabilities arising out of your non-compliance with the terms and provisions of this Notice.

This Notice applies to TI Resources. Additional terms apply to the use and purchase of certain types of materials, TI products and services. These include; without limitation, TI's standard terms for semiconductor products (<http://www.ti.com/sc/docs/stdterms.htm>), [evaluation modules](#), and [samples](http://www.ti.com/sc/docs/sampterm.htm) (<http://www.ti.com/sc/docs/sampterm.htm>).

Mailing Address: Texas Instruments, Post Office Box 655303, Dallas, Texas 75265  
Copyright © 2017, Texas Instruments Incorporated